

# A LIFE OF FLIGHT – European Pioneers of Early Aviation \*

*This study follows the life of aviation pioneer **Erich Schatzki** and highlights the careers of some of his peers. Schatzki worked in many different countries, starting in Germany where he was, until 1934, the technical manager of Lufthansa. He was party to the coming of American airliner technology to Europe and played later a creative role in the building of military and civilian aircraft in the Netherlands, USA and Israel. The story of Erich Schatzki is not just a story of aviation but also of the political upheavals of the 20<sup>th</sup> century.*

## 1. 1898 – 1991 Erich Schatzki and Family

---

*Erich Schatzki*, born January 23 1898 in Klafeld (Siegen) Nord-Rhein Westfalen, Germany. Died in Palo Alto, CA USA on August 28, 1991. German/American/Israeli pilot, aircraft designer, manager, entrepreneur and lecturer. Son of the Jewish engineer *Ferdinand Schatzki* (1857–1910), Oberingenieur at the Siegener Verzinkerei AG in Klafeld-Geisweid, Germany, and his wife *Beate Stern* from *Schmallenberg*.

*Erich S.* had four brothers, who all survived the Second World War. *Walter* became a book seller and antiquarian in New York; *Richard* a famous radiologist at Boston MA, where he discovered the so-called Schatzi-ring, a throat affliction. He loved music and had at home two Steinway grand pianos. *Paul* studied medicine and became a well known physician in Australia and *Herbert* was a textile manufacturer. Their lives were strongly marked by their Jewish lineage that forced them to flee their country of birth in the 1930's.



**Erich Schatzki (1898-1991)**

*Erich* studied engineering at Hannover and Darmstadt Technische Hochschule (1923). He received his Dr.-Ing. in 1929 at the Berlin Technische Hochschule. In 1933, after a successful career as a designer at Junkers-Flugzeugwerke AG and a pilot and Head of Engineering at Luft Hansa, he was forced to take refuge in Switzerland and later The Netherlands, where he designed fighter aircraft. He was forced to flee again in 1940. From 1943 to 1953 he worked as a design and development engineer for *Republic Aviation* on Long Island, USA, with a short interlude from 1949 to 1950 in Israel. After a stint as consultant in the USA, he lived again in Israel from 1958 to 1962, working for *Israel Aircraft Industries* as a Director of Engineering. From 1962 to 1970

---

\* This is version **ALIFEOFFLIGHT2.PDF**, compiled bij G.J. Staalman; August 2016 – Newport Beach CA.

he lived mostly in the USA, working as a consultant and as a design engineer. From 1970 to 1977 he was again in Israel, after which he was invited as a guest lecturer at *Stanford University*, California, USA. He remained at the West Coast till the end of his life in 1991, married to *Hedda Oppenheim*. His first wife *Bertha Schatzki* had died in 1969, leaving him a son, Thomas and a daughter, Karen.

## 2. 1920 – 1923 Erich Schatzki TH Study

---

1920 Akaflieg Darmstadt D-2 Pumpelmeise glider - design and construction by E. Schatzki and F. Hoppe

1923 Akaflieg Darmstadt D-7 Margarete glider – design and construction by E. Schatzki, F. Hoppe & R. Kercher



2

1923 Akaflieg Darmstadt D-7 Margarete

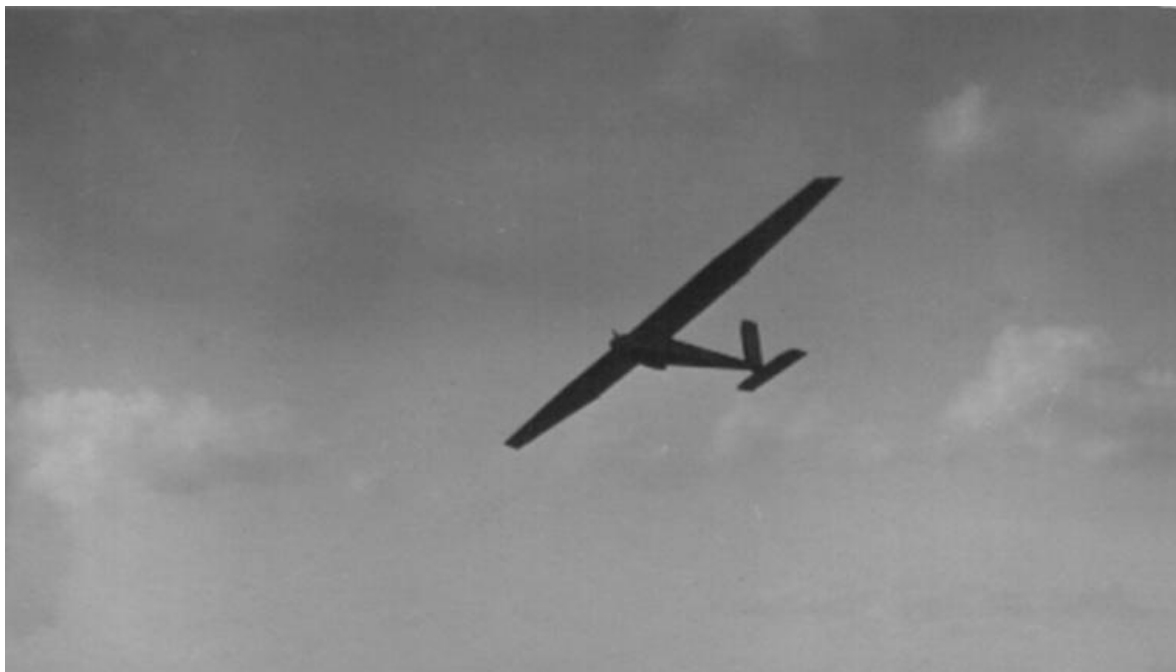

1924 Akaflieg Darmstadt D-12 Roemrijke Berge -- design and construction by Erich Schatzki  
– picture source [1]

### 3. 1924 – 1933 Erich Schatzki at Junkers and Luft Hansa

---

#### Promotion; Technical Functions; Fleet expansion

In 1924 *Eric Schatzki* joined Junkers-Flugzeugbau in Dessau as a Dipl.-Ing, specializing in airplane design. When in 1926 Deutsche Luft Hansa was formed out of a number of small German airline companies, Schatzki moved to Berlin and joined that company. He combined training for commercial pilot with studying for his promotion at the TH Berlin. He became Dr.-Ing. in 1929 with the dissertation: *Motorschönung durch Drosselung (Engine cleaning by means of throttling)*. He worked as a test pilot and later Technical Director at the airline company.



**Eric Schatzki designed the conversion of the single engine Ju-52 (ca. 1930) to the three engine version with Hornet radial engines (see below)**

As such he was in charge of the maintenance of a great variety of airplanes and directing the upkeep of a great collection of different airplane engines. He was also concerned with fleet modernization. He had to evaluate new additions and plan for a greater homogeneity. He conducted major engineering tasks such as the re-configuration of Junkers airplanes, changing them from three engines to one engine (W-34). Also the reverse: one-engine Junkers Ju-52 transport plane of 1930 into a three engine airliner, the Ju-52/3m (1932). The Junkers factory was reluctant to cooperate in this, but *Erhard Milch*, Luft Hansa's general director, got his way. The Ju-52/3m would become the mainstay of not only the airline, but also of German military transport during the Second World War. It was considered the safest airplane of the world. It was built in a total of 4845 units. *Erhard Milch* spoke very highly of Dr. Schatzki and called him "das technische Genie der Lufthansa." [2] [3]

In 1926 however, the most important task of the technical department of the young airline was to rationalize the motley fleet of the small companies that had merged into Luft Hansa. Germany had had extensive wartime experience with the design of large ('Riesen') bombers and it had also experience with the use of aluminium as a construction material for large planes. However, when in the after-war period multiple companies put this experience to use in the design of passenger- and mail-airplanes, a highly varied fleet of airplanes resulted. Also, the evolution of the large airplane was still in full swing and the designers were

looking for a definite form of the ideal airliner - present machines being slow and cumbersome. Improvements were certainly needed on the point of (aerodynamic) shape and more powerful engines with a low weight and low frontal resistance. Only in this way higher speeds would come within reach.



Ju 52-3m, powered by three 550 hp **Pratt & Whitney R-1340 Wasp** engines. (1932)



**Wright Whirlwind W5-A-J (1925)**

At the start of the thirties it was the *American* designers who unexpectedly took over the lead on these points. In the course of the 1920's the air cooled radial engine had been perfected by *Charles Lawrance* and the factories of *Wright* and *Pratt & Whitney* started producing a range of engines with ever increasing power ratings. These engines combined high power with low weight. At the same time *NACA* came with recommended forms for engine enclosures (cowlings) that reduced the frontal resistance of these engines dramatically, notwithstanding their blunt shape. With more powerful engines, designers could now turn their attention to smaller (monoplane) wings with reduced air resistance and thus greater airspeeds. At the same time they learned to build all-metal shell like structures for wings and fuselages. Eventually, in **1930**, the modern American mail plane appeared, the fast *Boeing Monomail* (metal, low mono-wing and retractable wheels) and shortly thereafter the short and medium range airliner (a larger plane of similar lay-out but with two engines).

In Germany, at the end of the twenties, the situation in the field of airliner design seemed to have reached a stalemate. Luft Hansa's technical development group under *Erich Schatzki* tried to stimulate the German manufacturers to develop machines of higher speed and passenger capacity. In **1932** a preliminary top was reached with the Junkers Ju-52/3m, which used American rotary engines and could transport 17

passengers at a modest maximum speed (200 km/h) over medium distances. There remained however a need for faster transport airplanes for airmail and high speed passenger travel.



Boeing Model 200 Monomail (1930)

5

#### 4. Orion, the Scoop of Swissair [4]



1932 Swissair buys 2 Lockheed Orions, fastest airliner in Europe and the only one with retractable wheels

On March 26, **1931**, *Swissair* - Schweizerische Luftverkehr AG ( *Swissair* - *Swiss Air Transport*) was formed through the fusion of the airlines *Ad Astra Aero* (founded in 1919) and *Balair*(1925). The founding fathers were *Balz Zimmermann* and the Swiss aviation pioneer *Walter Mittelholzer*. In contrast to other national airlines, they did not receive support from the government. In the first operational year 64 people were employed including ten pilots, seven radio operators and eight mechanics. In total, their planes offered 85 seats and operation was maintained only from March to October. The route network had a length of 4,203 kilometers.

*Swissair* seemed to possess a penchant for modern American airplanes. On April 17, **1932** they bought two *Lockheed Orions*, making them the second European airline to use American planes, after the Czechoslovak operator *CSA* purchased a Ford Trimotor in 1930. The Orion stemmed from a family of aircraft originally designed by *Jack Northrop*. Although of wooden construction, it might be considered the first of a series of revolutionary US designed airliners with retractable landing gear, stream lined fuselage, low wing monoplane configuration, powered by strong radial engines. Its maximum take off weight was 2350 kg and its maximum speed 350 km/h with a range of 1160 km. Its NASA-cowled power source was a Pratt & Whitney Wasp engine of 550 hp (410 kW). The Orion was the fastest commercial airplane of its time and was put to use on the "Express line", *Zurich-Munich-Vienna*. In **1933**, the first trans-Alpine route *Zurich-Milan* was introduced.

**Deutsche Luft Hansa was duly impressed (and nervous) and asked among others *Heinkel* for a machine that could top the Orion's speed, leading to the *Heinkel He 70* (see later).**

*Swissair* next bought two machines of the type *General Aviation GA-43*, a ten-passenger airliner very similar to the Orion but with state of the art, all metal construction. It was the brain child of the highly original American designer *Virginus E. Clarke*.<sup>[5]</sup> One more American purchase was the *Curtiss AT-32C Condor*,<sup>[6]</sup> an airliner used in the States as a Pullman sleeping car with an overnight capacity for twelve people. Its design was in conservative bi-plane fashion. *Swissair* used for the first time in Europe, flight attendants aboard the *Curtiss Condor* beginning in **1934**. *Nelly Diener*, first flight attendant, became world-famous. Unfortunately the *Condor* broke up in the air after just 79 flights because of metal fatigue in a crash near Wurmlingen, Germany, on July 27, 1934. All 12 passengers and crew, including Ms. Diener, were killed.

In **1936** all-metal *Douglas DC-2's* were acquired and London was added to the route network (see page 14). In **1937** the bigger *Douglas DC-3* was bought. In the same year, both founding fathers of *Swissair* died.

## 5. Rapid Airliners [7]

---

German civil aviation development after **1932** was influenced by two US planes: the *Lockheed Orion* (1932) and the *Boeing 247* (1934). The *Lockheed Orion*, with an eight passenger capacity introduced in 1932 by European competitor *Swissair*, had a performance (358 km/h max and 305 km/h traveling speed), which could barely be reached by fighter planes of those days. In **1933**, following the success of *Swissair* with the *Orion*, *Lufthansa* ordered two *Boeing 247*. One was going to be thoroughly tested by DVL at Rechlin, while the other one was to be tested out in line service with *Lufthansa*.

As *Ernst Heinkel* pointed out, it was no surprise that the Germans were overtaken.<sup>[8]</sup> At an earlier date, on June 26 **1929** DLH (*Deutsche Luft Hansa*) had specified: "...during a transition period, a traveling speed of 200 km/h would be acceptable (!) although the goal in the future must be 250 km/h. Motivation: higher speeds give a greater independence of weather and wind. However carefully shaped external forms are necessary – limiting the size of cabin and loading space. The desirable future 250 km/h traveling speed would imply a maximum speed of ca. 300 km/h.

A second report showed that the technical staff of *Luft Hansa* followed the developments in the USA carefully, but they had fixed their attention on a predecessor of the *Orion*, with lower performance. The second invitation to tender was sent to all aircraft builders with exception of *Junkers* and *Rohrbach* at the end of the year **1929**.

Heinkel reacted with 5 projects, one using the American radial *Hornet* engine; the DLH orders went however to the Focke-Wulf A.36 and BMW M.28. Both designs failed and were not even ready in **1931**, when in the USA the Orion, Boeing Monomail and Northrop Alpha caused a rightful stir.



### **The Heinkel 70, Germany's first answer to the modern American airliners of the thirties (1934)**

Next, as the result of yet another request, a single-engine Heinkel machine with liquid cooled engine was proposed, called *He 65*. A mock-up was intensely studied and discussed, especially the room for passengers in the limited fuselage space. DLH states that Heinkel guaranteed a maximum speed of 285 km/h, markedly lower than the 350km/h wished for by DLH. However, it had to be accepted as the maximum possible in Germany at that time. It was argued that higher speeds could only be obtained after having had experience with this first prototype and *by having available engines with greater power and lesser air resistance*. These considerations held also for the proposed Ju 60 and FW A.44. It was also decided to drop the wish for retractable wheels for now.

The resulting compromise was obviously not the plane that DLH had desired. What had seemed out of reach became however possible, not by the pressure of the client, but by the revolutionary performance of Swissair's Orion at its European appearance in **1932**. Heinkel's construction team made a thorough revision of its design for the rapid He-65 and came up with the *He 70*, a design that equaled, if not surpassed, the American competitor in speed.

The highly streamlined all-metal *Heinkel 70* was Germany's first answer to the modern American airliners of the thirties. Its powerplant was a BMW VI water-cooled V12 engine of 750 pk (552 kW). It had the same performance features as the Lockheed Orion with a maximum take off weight of 3500 kg and a maximum speed of 360 km/h. Its range was 2100 km. It, however, could only carry four passengers and it was considered by some to be a fire hazard. From **1934** on Lufthansa used it for nightly mail routes and on its mail route to South America on the stretch from Stuttgart to Seville (Spain). The same type of airplane was later developed for the Luftwaffe into a light bomber.<sup>9</sup>

## 6. Pionier at Luft Hansa: Carl August von Gablenz



**Carl August Heinrich Adolf von Gablenz (1893-1942)**

*Carl August Heinrich Adolf von Gablenz* was born on Oktober 13 **1893** in Erfurt, Germany. He died during the Second World War in a mysterious airplane accident on August 21 **1942** near Mühlberg on the Elbe in central Germany. He was a great aeronautical pioneer, both in civil and military aviation, and ended his life as a Major-General of the German air force.



Following his noble family's obligation he joined the Prussian Army as a 'Fahnenjunker' (officer-cadet) after completing his classical high school education in **1913**. At the start of World War One he was a first-lieutenant. As the result of a bullet wound in his knee he became unfit for the infantry and had to change to Germany's fledgling air force. There he earned great merits, first as a flight observer, later as a pilot on all sorts of warplanes, including, during the last year, as a captain on large four-engine long range bombers. After the war he became a pilot for the *Deutsche Luft-Reederei*, a small company which found its origin in the military with a base in Berlin. It was supported by such civilian companies as AEG, Hapag, Luftschiffbau Zeppelin and the Deutsche Bank. In **1924**, as a highly experienced pilot he joined *Junkers Luftverkehr AG*, where he became a specialist in technical matters such as the development of reliable all-weather engines.

When in **1926** *Deutsche Luft Hansa* was formed as the amalgamation of the existing small German airline companies such as Junkers Luftverkehr, *von Gablenz* became the manager of flight operations. Under the general direction of *Erhard Milch* (also from Junkers) *von Gablenz* developed the basis for the modern practice of instrument ('blind') flying. He had to overcome great resistance among the traditional flight crews and had to force them to follow strict trainings courses to master the technique of instrument flight. This effort paid off when it later came to the creation of a European net of nightly air mail delivery, in which Luft Hansa took the lead.

In **1933** *von Gablenz* became a member of the board of Luft Hansa. He concentrated on the establishment of connections across the Atlantic. He himself executed the first trial flights across the North and South Atlantic and was able to establish the first regular mail service to South America using a combination of fast planes, flying boats (Dornier Wal) and midway stationed supply ships such as the steam boat Westfalen.

The network of Luft Hansa was continually extended by the tireless efforts of *von Gablenz*. In September **1934** he flew a Junkers Ju 52 from Berlin to Shanghai. In **1936** he was captain on the first regular flight from Europe to New York. In August **1937** he received great international attention when he started with the Luft Hansa Junkers Ju-52 *D-ANOY* on a reconnaissance flight to the Far East. After an emergency landing in Chotan, in Chinese Turkestan, the crew was kept prisoner for four weeks by local war lords. He writes in detail about these adventures in his book published in 1937. The passage of the Pamir Mountains through the Wakhan pass at a height of 5,300 meter (16,000 feet) was a feat which caused a great international stir. When the pioneers, who had been considered lost, finally returned on October 3, 1937 on Berlin-Tempelhof, they received a true heroes-welcome.

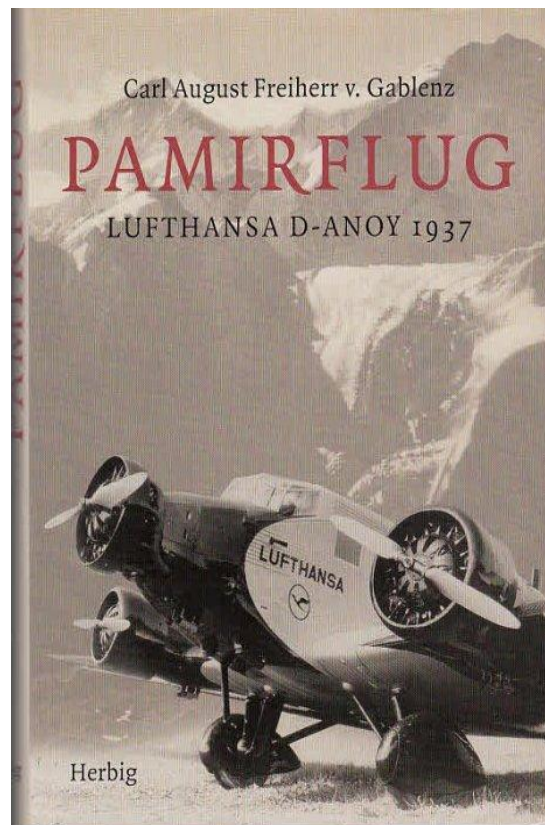

## 7. The Nazi's Take-over [<sup>10</sup>]

---

### 1931

☒ July: American and German banks collapse and are temporarily closed; In Germany payments of benefits to the unemployed are slashed.

☒ General recession.

☒ October: daily violence in the Berlin streets by SA and SS.

### 1932

☒ May 30: Crisis in cabinet: von Papen becomes Chancellor.

☒ July: Hitler's NSDAP gets by 239/680 vote a Reichstag (parliamentary) mandate; Hermann Goering becomes Chairman Reichstag.

☒ The unemployment situation is appalling. In the industrial region Bremen, one quarter of the labor force is without work.



**Erhard Milch (1892-1972)**  
**General Director Lufthansa (1926),**  
**Deputy Minister of Aviation (1933),**  
**Generaloberst (1938)**

### 1933

☒ Beginning of 1933: 6 million Germans out of work (nearly 10% of the population). [<sup>11</sup>]

☒ Von Papen negotiates with Hitler about a new cabinet.

☒ January 30: Hindenburg appoints Hitler to Reichskanseler (Chancellor).

☒ February 27: Reichstag fire

☒ Takeover of government by Nationalsozialisten.

☒ Establishment 'Reichskommissariat für die Luftfahrt'. [<sup>12</sup>] The Nazi's want a powerful aviation industry in order to create in a short time a modern air force.

October 18 **1933**: The nestor of German aviation, *Prof. Hugo Junkers*, who is a pacifist and who has so far out of principle refused to bend to the dictates of the Reichsluftfahrtministerium, is forced, during a “Nacht und Nebel” operation, to relinquish ownership of his patents and his enterprises. He is banned from the city of Dessau, the seat of the Junkers aircraft factories, to Bayrischzell, where he dies one and a half years later on his birthday, February 3, **1935**, at the age of 76. The elimination of the headstrong old gentleman, an obstacle in the plans of the RLM, has been masterminded and directed by *Erhard Milch*, his former adjunct.

[Pophanken] The Junkers works are now under complete control of the Nazi government and are being reorganized for the accelerated production of military aircraft in the rearmament program of the Luftwaffe. Hitler’s men have taken over complete control, both of Lufthansa and of the Reichsverkehrsministerium. The whole top of the aviation world is in the hands of *Göring* and his World War I compatriots (cronies). His comrade flight-observer *Erhard Milch* (formerly director DLH) is now Stabssekretär (first deputy) and in charge of aircraft procurement at the newly formed Reichsluftfahrtministerium (RLM) and is eventually promoted to Generalfeldmarschall.

### **1934**

☒ Politically the situation becomes deadly. The night of June 30 is known as the ‘Night of the Long Knives’. Hundreds of rivals to Hitler’s power are murdered by the SS.

*For all functionaries of the government, whether they are (engineers) working for the aircraft industry, Lufthansa, teachers and staff members of schools or universities, the question of ‘Arian’ heritage becomes the criterion for continued employment. As a first phase in the extermination of the Jewish part of the population, all persons who can not show proof of having white, ‘Arian’ grandparents are denied the possibility of work. Those affected who are physically and financially strong enough consider seriously leaving the country. Many Germans of Jewish descent go into exile into European countries or the Middle East or Turkey or the USA. Some flee to bordering countries like France, The Netherlands and Denmark, but after their occupation by Nazi Germany in 1940 Jews are no longer safe there either.*

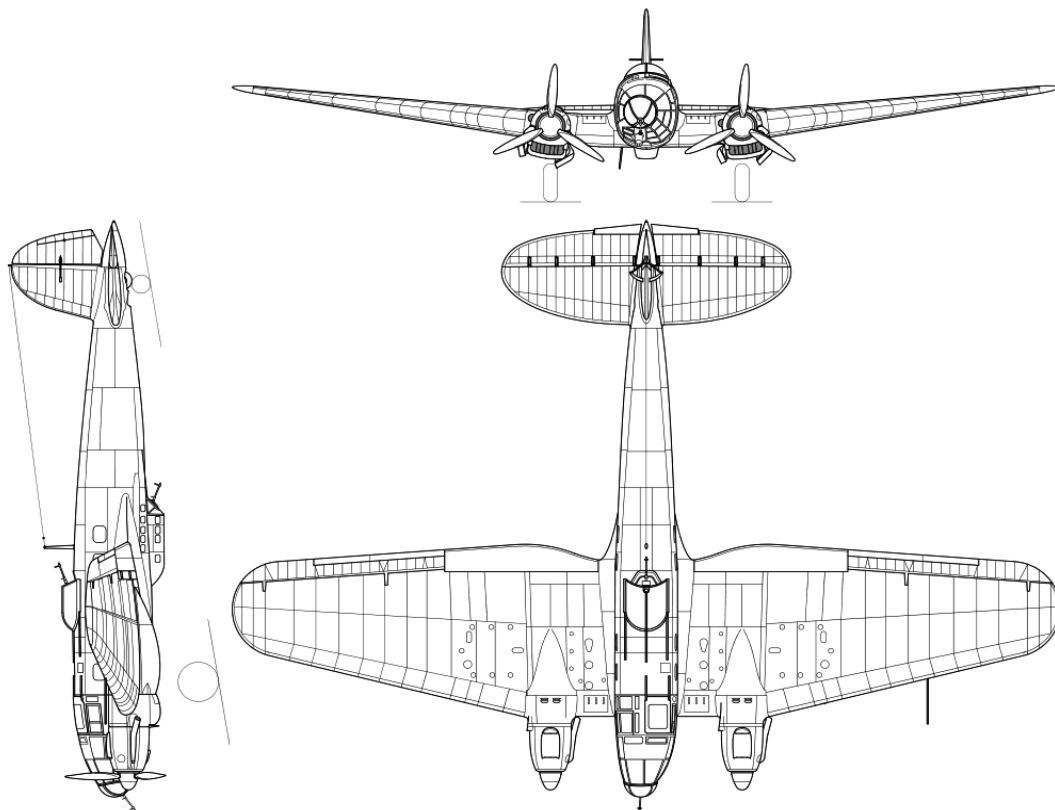

**Heinkel He-111. Originally developed as a fast airliner for Lufthansa similar to the Boeing 247 (1934) It became the most versatile light bomber of the Luftwaffe, with nearly 8000 produced [Wiki]**

## 8. End of Schatzki's Career in Germany



1933: Boycott of Jewish stores in Germany (source: Wiki)

In **1933** the German authorities decided to order three American *Boeing Model 247* two-engine airliners for evaluation in Germany. *Hermann Goering* himself justified the purchase:

*"Because of the immense financial resources at their disposal the foreign, and in particular the American, aircraft industry has been able to gather in many respects a number of experiences of much greater scope than the German aviation industry has been able to during the last years. The purchase of foreign airplanes for the German airlines should be considered as an opportunity to compare in daily praxis our products with the best machines made in America."*

The order must have gone through at the same time that DLH's technical expert, *Erich Schatzki*, got into a dismal work situation with his employer. Because of his Jewish descent, he had become in **1933** more and more the subject of isolation and pressure from the National Socialists who were active at Lufthansa. In every walk of life the question of one's Jewish ancestry became a highly controversial topic of discussion. At universities, state agencies and also commercial organizations functionaries accused each other of not being 'pure Arian'. Those with Jewish 'blood' were forced to leave. Even highly placed people had to legitimize themselves. Goering himself became involved in declaring that Erhard Milch was an 'Arier'. Ernst Udet even accused von Gablenz of having Jewish ancestors. Many famous Jewish professors, scientists and writers were forced to go into exile.

Erich Schatzki describes as follows this dismal episode of his life:

*"I remember how Dr. Grulich [a long time colleague] visited my office, where he told me, with a demoniacal smile, that my position in the Lufthansa was impossible, because I was Jew. He did not know that I had already made up my mind to leave the Lufthansa anyhow, because I did not want to work with any part of Hitler's Germany".*<sup>[13]</sup>

It is possible that Erhard Milch, who supported Schatzki, aided him in finding an ingenious way out of the situation by sending him at the end of **1933** on a fact finding mission to the United States. It may also be that Schatzki went there (via Switzerland?) of his own accord. One way or the other, in the beginning of **1934** Erich Schatzki turned up in the USA to inspect for Lufthansa and Swissair the new generation of American airliners that had been ordered for Europe.

He is interviewed by an American trade journal [<sup>14</sup>] which leads to the following comments on the difference between American and European airline operations:

### **America Leads**

"The United States is fully two years ahead of European countries in development of aircraft for general air travel." Such is the frank admission of Dr. Erich Schatzki, one of Europe's outstanding aeronautical engineers who is in this country inspecting the general operation of United States air lines, their maintenance bases and the new planes which will soon be in operation along the nation's airways.

Dr. Schatzki made this statement after a thorough inspection of the huge maintenance base and operations headquarters of Transcontinental & Western Air, Inc., at Kansas City. "It is true," Dr. Schatzki continued, "that we have in Germany a plane which is faster than any of the planes you have in operation or under construction, but it is also true that it carries only half the load of some of your single motor planes which are nearly as fast."

"The major air lines in the United States," Dr. Schatzki said, "have a big advantage over the European lines because here it is possible to centralize control to a greater extent, making for a less costly as well as a more efficient operation. Most of the American lines have been able to locate their operations and maintenance headquarters mid-way on their transcontinental lines. There is no "mid-way" on many of the European lines because they extend in all directions rather than in a direct east-west or north-south line.

"European airlines have not found the reliability in their motors that American lines have provided," Dr. Schatzki said, "and for that reason European lines find it necessary to carry a 100 per cent reserve of spare motors. If there are fifty motors in daily operation on any line, there are also fifty motors held in reserve at the various repair depots."

Dr. Schatzki is decidedly in favor of the present American trend toward twin motor airplanes to supplant the tri-motor planes now in general use. "The twin-motor plane, I believe," Dr. Schatzki said, "will develop greater safety as well as greater efficiency for it will develop a much higher cruising speed with little or no increase in its landing speed."

While in *Seattle* for the *Boeing* factory (see next page), Erich Schatzki had an intensive meeting with *Anthony Fokker*, the Dutch airplane builder who now lived permanently in the United States. After accomplishing his task with Boeing, Schatzki returns to Germany only briefly in order to move his family to the *Netherlands* where he has accepted a position with the home base of the Dutch aircraft manufacturer in *Amsterdam*.

In Amsterdam the Schatzki's will live at the Minervalaan, in a new city district with a well-to-do, partly Jewish, population.<sup>15</sup>

*Ernst Heinkel* will testify later about this episode:

„...[Ich traf in Berlin] den für die technische Entwicklung verantwortlichen Mann der Lufthansa, Dipl.-Ing. Erich Schatzki. Schatzki war jüdischer Abstammung und ein ausgezeichnete Ingenieur und Flieger. Dazu war Schatzki menschlich von einer gewinnenden Art. Die Art, wie ihn die Lufthansadirektion 1933 fallen ließ, gehört nicht zu den Ruhmesblättern der Beteiligten.“ [<sup>16</sup>]

or in short English:

“...[I met in Berlin] Dipl. Ing Erich Schatzki – the man who is responsible for the technical development at Lufthansa. He is from Jewish origin and an excellent engineer and pilot. On top of that he is a most amiable Mensch. The way he was let go by the direction of Lufthansa in 1933 does not do credit to any of those who were involved...”

## 9. Erich Schatzki's Flight; Visit to the USA

In **1933**, at the request of the German *Reichsluftfahrtministerium* (RLM), Deutsche Luft Hansa (DLH) placed an order for three Boeing airplanes in the USA. [17]

*Dr. Erich Schatzki*, who was the former director of the Technical Development Department of DLH and a champion of the concept of rapid air transport, was already in the USA in January **1934**. Soon after the seizure of power by the Nazi's he had, as a Jew, been forced under truly degrading conditions to terminate his employment with Luft Hansa and he was now on his way into exile. Ignoring these embarrassing circumstances, he received via the German embassy in Washington on January 17 **1934** the request and the authority from Lufthansa to formally accept the three *Boeing 247* machines that were on order, as well as six Vought V85G *Corsair* airplanes\*.

With the conscientiousness that was his own and despite all bitter feelings, he accepted this last request of his former chief *Erhard Milch*, who now had advanced from Director of Lufthansa to Deputy Minister of Aviation. On January 30, 1934, after having talked to *Mr. Hamilton* of *United Aircraft Exports Inc.*, Dr Schatzki informed Berlin that the first two Boeing 247 were scheduled for shipment by sea on February 13, 1934, while the shipment of the third machine was scheduled for March. Observing that the Boeings had been tested as a matter of routine procedure, Mr. Hamilton intended to ship the already disassembled and packed machines without further test flights. He did offer to send two pilots to Germany for demonstration flights. But *Dr. Schatzki* was no novice in the matter of acceptance trials. At the risk of an inevitable delay in the delivery schedule he insisted that the machines would be reassembled and undergo their full acceptance trials in the United States.

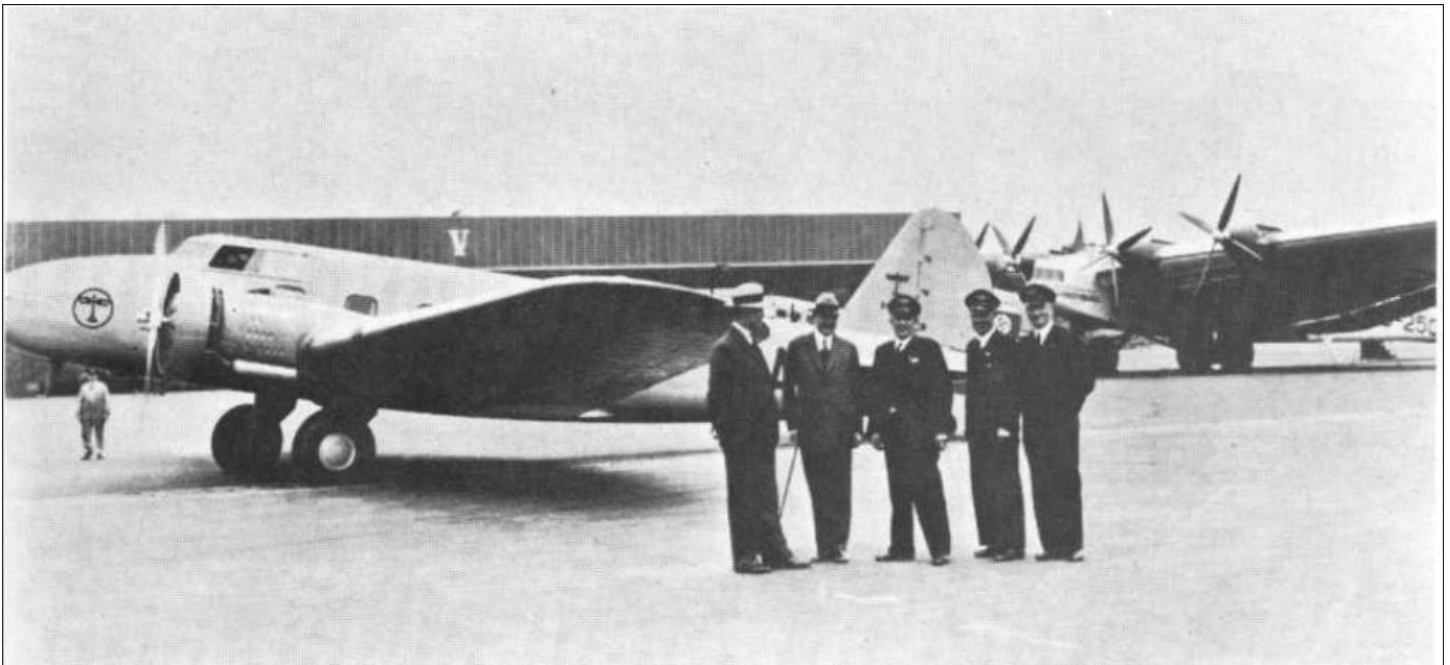

**April 6 1934: Boeing's representatives introduce the D-AGAR (Works Nr. 1945) at Tempelhof, Berlin**  
In center **Carl A. von Gablenz, Director DHL** [picture credit: [Günther Ott](#)]

\* From 1929, the German Norddeutscher Lloyd-liners *SS Bremen* and *Europa* were fitted with catapults to launch mail-planes. These ships served the route between Germany and the United States. The aircraft, carrying mail-bags, would be launched while the ship was still many hundreds of miles from its destination, thus speeding mail delivery by about a day. Initially, Heinkel HE 12 aircraft were used before they were replaced by Junkers Ju 46, which were in turn replaced by the *Vought V-85G*. [source: Wiki]



**Lufthansa's Boeing 247 at Schiphol, Amsterdam (1935?) with Dutch flag on tail** [picture: Günther Ott]

On February 16 **1934** the first Boeing 247 (Work no. 1944) passed acceptance tests in the USA and one week later the second one (Work no. 1945). They must have arrived in Germany March/April 1934. By that time a comparison could be made with the mock-ups of the German designs for the Do 17, Ju 86 and He 111. The delivery of the third Boeing machine was delayed because of a wish of the client to change the engine to another type. Later on it appears that the order for this machine was cancelled altogether.

*Dr.Schatzki* was then asked to investigate the price and delivery options for a Douglas DC-2 and a Northrop Gamma. It is certain that *Dr.Schatzki* for this matter came into contact with *Anthony Fokker*. *One of the outcomes of their meeting was that Anthony Fokker hired Dr.Schatzki for his factory in Amsterdam in the Netherlands, in the position of Chief Designer.* Fokker had acquired the exclusive sales rights for Europe of Douglas aircraft and all deliveries were made through his Dutch factory. Lufthansa did indeed receive a DC-2 along these channels, but nothing further is known about the Northrop machine.

Prior to the World War II, the Douglas DC-2 became the principal type of twin-engine airplane used by Swissair on its main routes. It was used to inaugurate the Zurich-Basle-London air service, the 450-miles stage from Basle to London being probably the longest regular non-stop schedule in Europe at the time. The DC-2 had space for fourteen passengers and the crew included a stewardess for serving refreshments, etc., in the air. Swissair owned 6 DC-2's in the period from 1934 to 1952. They were all Douglas-Fokker DC-2's, meaning they had been assembled and test flown in Europe by Dutch Fokker personnel.<sup>[18]</sup>

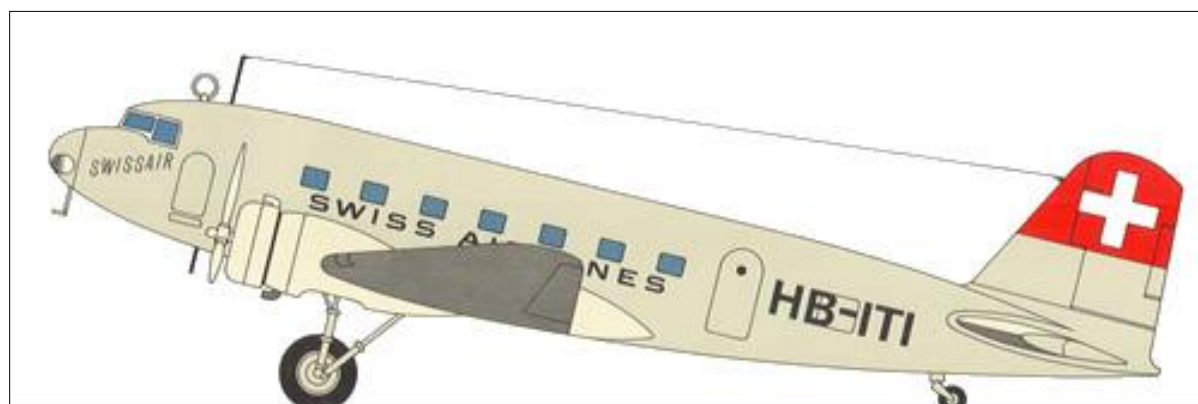

**Swissair Douglas DC-2 (1934)**

## 10. Anthony Fokker

---



**Anthony Fokker (1890-1939)**

**Anthony Fokker** is to this day one of the most admired Dutch aviation pioneers. He was an excellent (test-) pilot, builder of aircraft, entrepreneur and promoter of himself and his products.

He was born in *Kediri, Java, Dutch East Indies* (now Indonesia) on April 6, **1890**. His father was a well to do planter who returned to The Netherlands in 1894. On August 31, **1911** (the festive birthday of the Dutch queen) Anthony surprised the burghers of Haarlem (a city 15 miles west of Amsterdam) by flying circles around the old St.Bavo church steeple at the city center in a *home-built airplane*, the *Spin* (Spider).

During the First World War he earned fortune and fame building fighters for the German air force, while located at Berlin-Johannisthal and Schwerin. He followed his own particular method of airplane construction, relying for a great part on the skill of those he employed. He had an excellent welder, *Reinhold Platz*, for the design and assembly of tubular steel airframes, while he adopted an all wooden wing structure developed for him by the Swedish engineer *Villehad Forssman*. [<sup>19</sup>] While his designs evolved from monoplane, bi-plane, and tri-plane back to monoplane, he adhered during his whole building career to this method of “mixed construction”. His own main contribution, apart from sales, was test flying his new creations and finding out faultlessly where design modifications were needed (length of rump, shape of rudder, etc.). Also, most useful, he invented and patented an installation for firing machine guns through the path of an airscrew.

When the war ended, he loaded his stock and factory equipment on several freight trains and returned to the Netherlands where he obtained a factory just north of Amsterdam. He next turned to *airliners*, all the while remaining faithful to his method of mixed construction. His first model was the *Fokker F-II* (**1919**). The US Army T-2 (a modified *Fokker F-IV* airliner) is on permanent display at *The Smithsonian Institute in Washington*. It flew non-stop across the USA (4000 km) in **1923**. [<sup>20</sup>] In his own country Fokker became the principal supplier for *KLM*, the national airline. He developed a whole series of airliners that formed the

backbone of colonial communications: the airway between Amsterdam and Batavia (now Jakarta, Indonesia). One of his most renowned models was the *Fokker FVII-3m*, a three-engine high wing airliner that also served *Kingsford-Smith* for his trans-oceanic flights and *Richard Byrd* for his Polar explorations.



**'Southern Cross', Sir Kingsford Smith's famous Fokker F.7-3m (1928)**

In **1924** Fokker sensed a growing market in the United States and he founded a branch of his company in that country called *Atlantic Aircraft Corp*, later *Fokker Aircraft Co of America*. His general manager was Mr. *Bob Noorduy*n.<sup>[21]</sup> They found a receptive market for airliners and sold a relatively large number of machines like the *Fokker F.10*, a further development of the European Fokker models. A major setback occurred in **1931** when a TWA Fokker plane crashed in the Kansas mountains killing all 8 people aboard, among whom Notre Dame legendary football coach *Knute Rockne*. Investigations pointed to failure because of poor maintenance of the wooden wing and the findings shook Fokker's reputation.

Anthony Fokker did not feel inclined to make a major change in design practice and to switch over to all-metal airplanes, but he had a keen eye for what was happening in the American market and he sold his company in **1931** to General Motors, where it became known as *General Aviation Manufacturing Corporation*. It in turn merged with *North American Aviation* and was divested by GM in 1948. In **1931**, discontented at being totally subordinate to GM management, Anthony Fokker resigned. <sup>[22]</sup> He then acquired the exclusive sales rights for *Douglas* aircraft in Europe. His factory in Amsterdam was responsible for the assembly of the Douglas machines, in this way becoming familiar with the latest American metal-engineering technology.

After **1932** Fokker did make in fact a concerted effort to build more modern airliners for KLM, his principal customer in Europe. He stuck, however, with his proven 'mixed mode' of construction and fixed, non-retractable landing gear. He did manage to extend substantially the capacity of his airplanes to 22 (Fokker F.XXII) and respectively 36 passengers (Fokker F.XXXVI). The resulting planes were streamlined, large machines, with four engines, but did not really meet KLM's requirements. The company preferred to change

over all together to the all-metal Douglas airliners. In fact in **1934** KLM won the second place in the spectacular England-Melbourne race with the *Douglas DC-2 'Uiver'*.



**Fokker did have a go at an airliner with retractable landing gear. On this photograph Anthony Fokker and ir. Marius Beeling in the cockpit of the Fokker F.XX (1933), discussing where to put the controls for the gear** <sup>[23]</sup>

The three-engine, 12 passenger F.XX was still of 'mixed construction' and remained a one-of-a-kind. It ended up with the Spanish Republicans in Spain and crashed there in 1938. \*)

It is in this rather fluid situation of hesitant company strategy that Anthony Fokker catapulted his new selection for Head-of-Design, *Dr.-Ing. Erich Schatzki*. Peter de Jong suggests that in March **1934** Fokker simply notified the Chairman of his Board, *Vattier Kraane*. <sup>[24]</sup> Whether *ir. Marius Beeling*, the sitting Head of Engineering, was consulted at all, is not known. It is a public secret however, that Anthony Fokker was no great admirer of 'academic' aviation specialists and that he admired people with practical experience in flying as well as engineering management. In this respect ex-Lufthansa's *Dr.-Ing. Schatzki* was his man. It would appear from further newspaper dispatches and photographs that the newly arrived staff member took his proper place in the factory hierarchy as Chief of Design. Whether he was really fully accepted by his seniors and co-workers is an open question.

---

\* Note: The above picture comes from the amazing site:

<http://www.dutch-aviation.nl/index5/Civil/index5-2%20F20.html>

This site (in English) is an excellent portal to Dutch aviation history, with special emphasis on KLM and Fokker, both the person and his companies. You will find there more details on the Fokker F.XX - a last attempt of Fokker to design an airliner that would be able to compete with the, in 1930, up and coming American all-metal machines, such as the Boeing Model 247 and the Douglas DC-2.

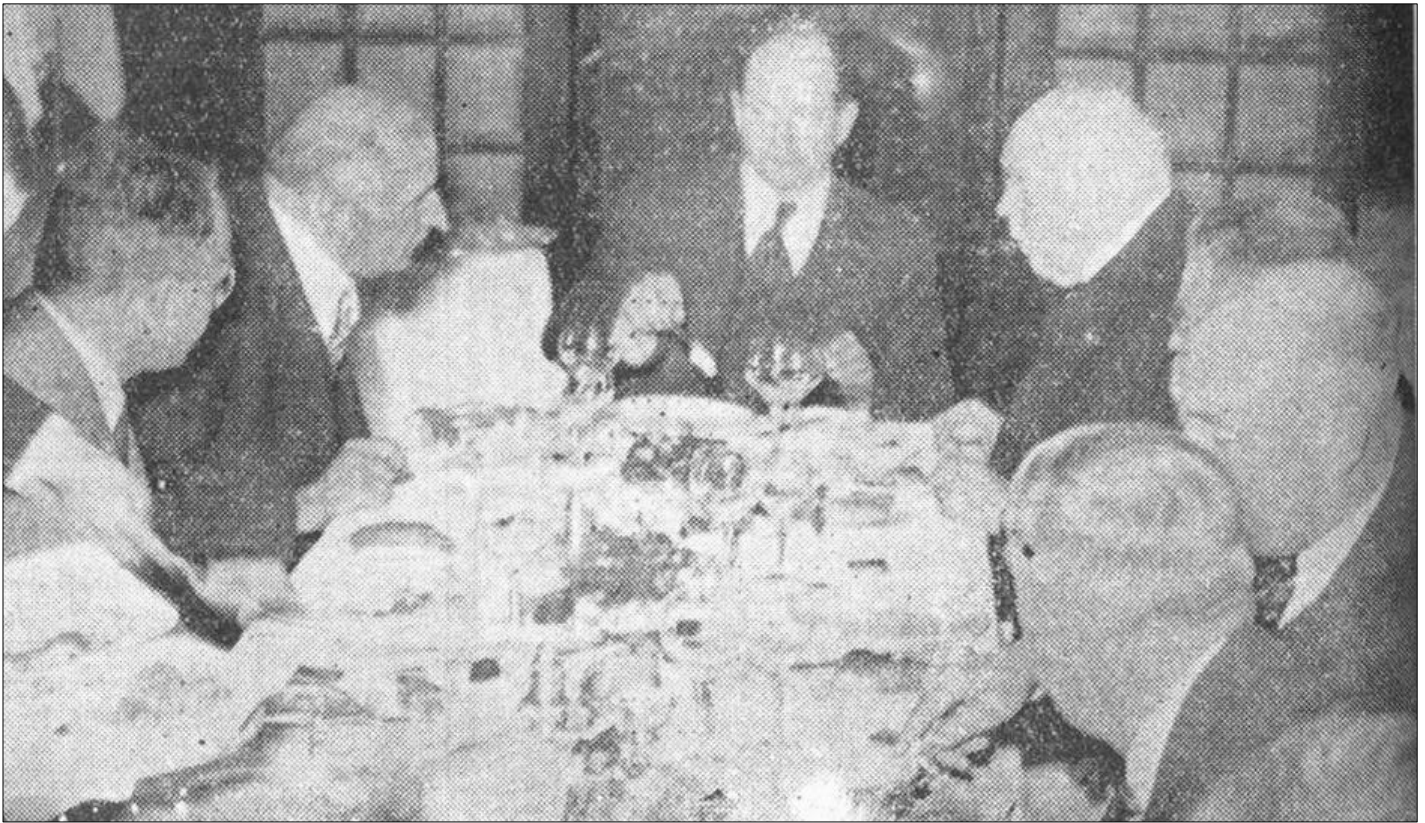

**When ir. Stephan left for Turkey, he enjoyed a farewell luncheon at the Carlton Hotel in Amsterdam (November 14, 1935). From left around the table: Schatzki, Stephan, Anthony Fokker, Vattier Kraane, Elekind, Janse en Smit Kleine. [source, via Delpher<sup>25</sup>]**

As *Dierikx* writes about Anthony Fokker:

“... his involvement in running his Dutch company diminished [at the end of the thirties].

*[Anthony]* Fokker's withdrawal worked out to be a blessing, for it freed his new deputy director, *Jacob van Tijen*, who had succeeded *Stephan* in Nov. **1935**; designer *Erich Schatzki*, a refugee from Nazi Germany who had been hired in **March 1934**; and chief engineer *Marius Beeling* to pursue a course of their own...” [26]

*Following the major political events at the end of the thirties, their course led to a renewal in the activity of the company with respect to military aircraft for the Vliegtuigafdeling (the Netherlands Army Air Force) and also for the export.*

On December 23, **1939** Anthony Fokker died at age 49 in New York from pneumococcal meningitis, after a three-week-long illness. In 1940, his ashes were brought to Westerveld, North Holland, where they were buried in the family grave. [27]

## 11. Erich Schatzki's Flight; Work at FOKKER, Amsterdam

---



**One of Fokker's white elephants: the 22-passenger F.XXII.  
Only 2 of the 4 engines are shown on this photograph**

Upon arrival at his new employer in March **1934**, Erich Schatzki took immediately part in the work at hand, such as the testing of the C-10 reconnaissance airplane and the F.XXII airliner. Next, at the request of the colonial air force in the Dutch East Indies, the factory undertook a study for a modern low-wing fighter plane which received the designation *D.XXI* (or *D.21*). Schatzki worked on this plane as head of the design team and later made test flights in it. The D.XXI had the typical Fokker mixed construction: wooden wings, steel-frame hull. Also, rather Fokker-like, it could not retract its wheels. It was originally conceived for the Dutch East Indies, but was later sold to the Danes, to the Fins (who would build it under license and fight the Russians with it) and even to the own military Dutch Luchtvaart Afdeeling (LVA) in 1938. The total number delivered by **1939** came to 148. Its maximum speed was 460km/h (see Table 1).

20

**Fokker DXXI at present Soesterberg Airforce Museum (source: Wiki)**

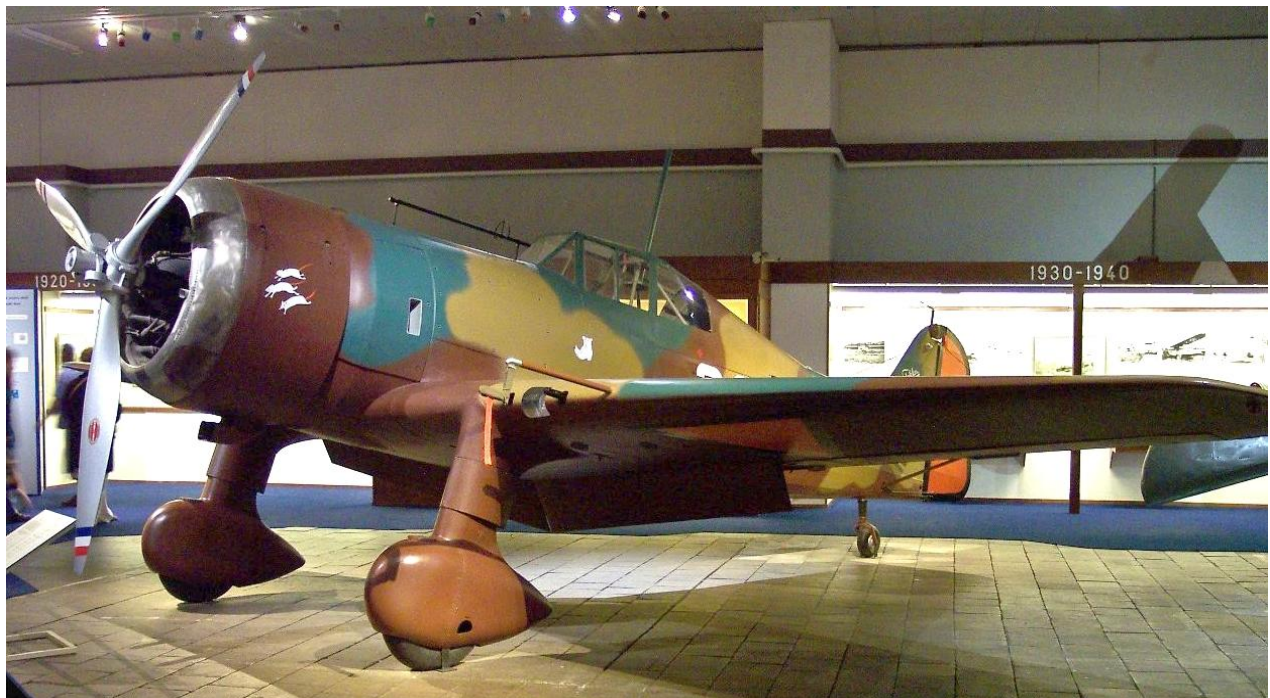



..."The first three men to fly the D.XXI pose in front of the prototype after its maiden flight. Capt Van Lent shakes the hand of veteran factory pilot Emil Meinecke, while to the left of them is Fokker's chief constructor, *Erich Schatzki*, who had never designed or flown fighters before, but did fly his own brainchild. On the right is Fokker flight-test engineer Frans Stok. The wheel fairings and a cockpit canopy were not fitted for the first flight." [(T. Postma) © Osprey]

...Owing to soggy conditions at Amsterdam's Schiphol Airport, the prototype, powered by a 645 hp Mercury VI, first took to the air from Eindhoven's Welschap airfield on 27 February **1936**, flown by 43-year-old factory pilot *Emil Meinecke*. *Bertus Somer*, a young flying instructor and former fighter pilot, was subsequently engaged for spinning trials, but he panicked during an early test flight and nearly crashed the aircraft on May 1, spreading word that the D.XXI was dangerous. To make matters worse, the colonial Dutch air force had meanwhile decided to buy bombers rather than any fighters, and the metropolitan Dutch Army deemed the D.XXI too slow. Former Messerschmitt test pilot '*Bubi*' *Knoetzsch* had to be flown in to establish that spin recovery in the D.XXI was, in fact, normal, although the type was prone to stalling into a spin owing to its 'flat' wing, which had little dihedral and no washout. Famous French aerobatic pilot *Michel Détrouyat* also went to Amsterdam to fly the D.XXI, and insisted that lateral stability should be increased.

*Ilmavoimat* (Finnish Air Force) *Capt Gustaf 'Eka' Magnusson*, who flew the prototype on 8 July **1936**, did not share Détrouyat's dim view, however, finding it a sharp, responsive fighter. The D.XXI's time-honored mixed construction was also light yet strong, giving the aircraft good climbing and diving characteristics. As a result of Magnusson's recommendations, Fokker's seemingly ill-fated fighter emerged as the leading contender in Finland's **1936** fighter contest.... [28]

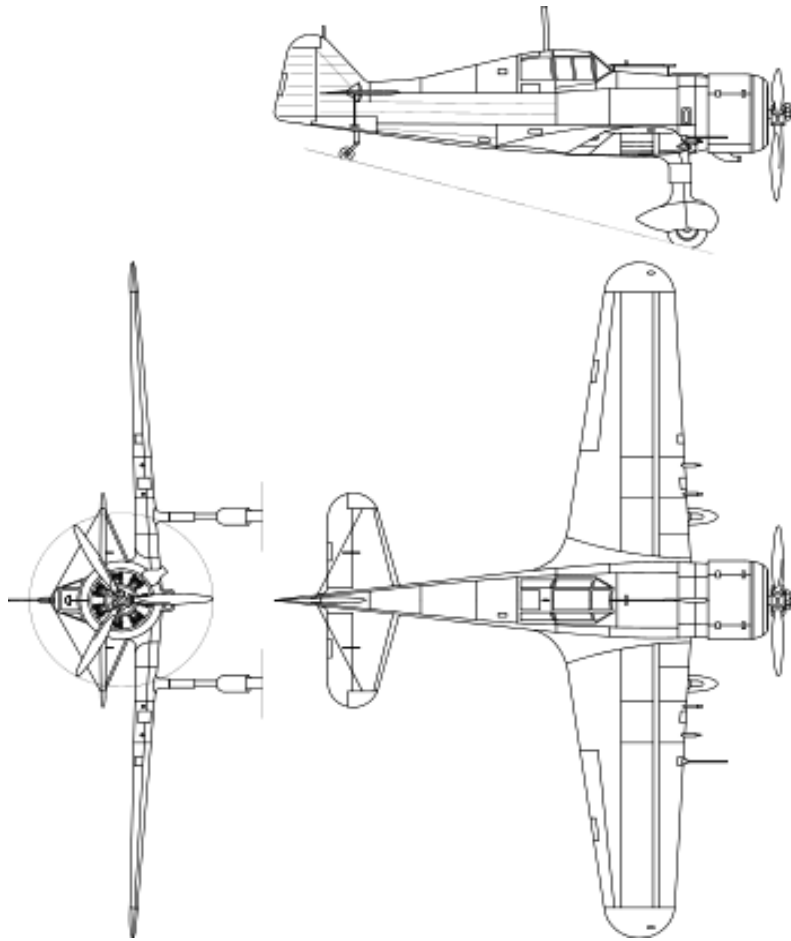

**Fokker D.XXI (1936)**

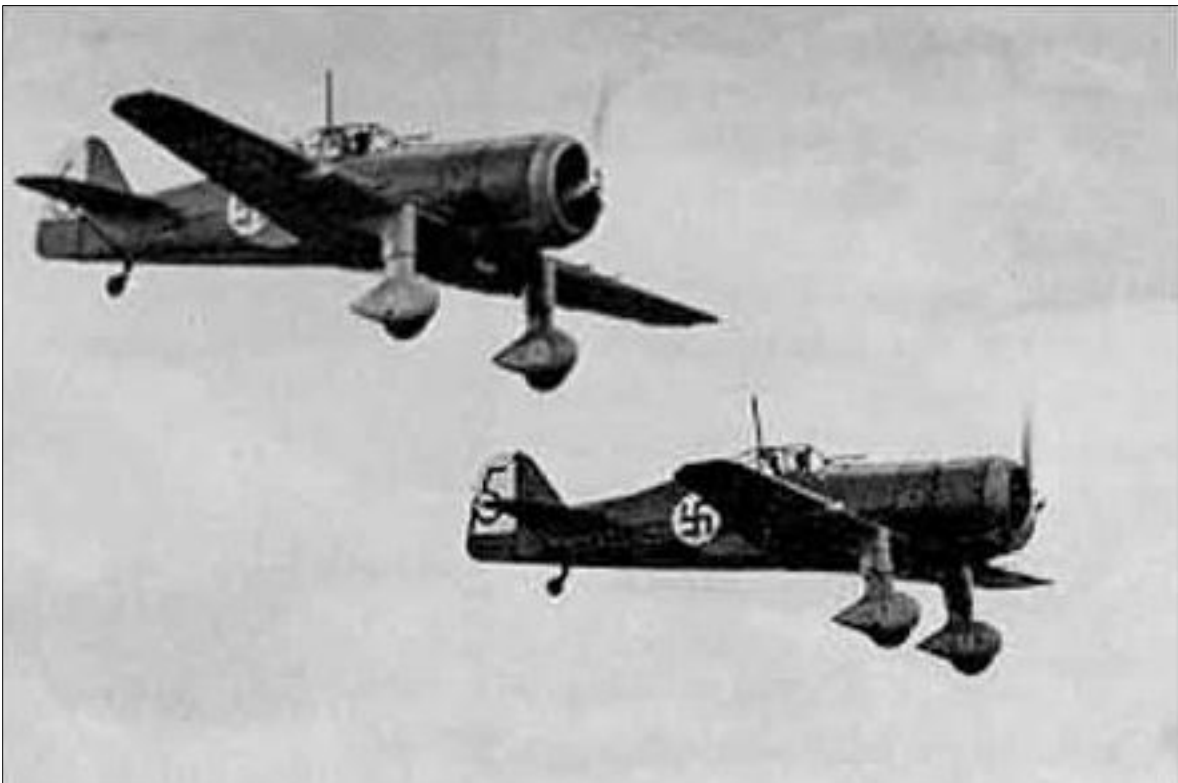

**Fokker D.XXI's of the Finnish air force (1939)**

## Fokker G.1

Fokker's Dutch design team with *Dr. Schatzki* then embarked on a most ambitious design for what was called a 'jachtkruiser' (Wiki: "heavy" fighter or "air cruiser", able to gain air superiority over the battlefield as well as being a bomber/destroyer), with a role comparable to the Me-110 and anticipating by a couple of years the *Lockheed P-38 Lightning*. The *Fokker G-1*, a two-engine, heavily armed fighter, had two engines that were at the front-end of double tail booms. In seven months time the plane was designed and built, ready for the **1936** Air Show in Paris, where it caused a sensation. Its first flight was one year later.



**YESTERDAY FOKKER'S NEW HEAVY FIGHTER, THE G.1, took for the first time to the air at the Eindhoven airport 'Welschap'. Shown here, just before take-off, from right to left: chief-designer Schatzki, the Czech pilot Mares, who flew the plane and ir. van Tijen, vice president of the Fokker company. (Mar 17, 1937)**

"The **G.1**, given the nickname *le Faucheur* ("reaper" in French), had the role of jachtkruiser, ("heavy" fighter or air cruiser), able to gain air superiority over the battlefield. As a fighter as well as a bomber and destroyer, the G.1 would fulfill a role seen as important at the time, by advocates of *Giulio Douhet's* theories on air power. The Fokker G.1 utilized a twin-engine, twin-boom layout that featured a central nacelle housing two or three crew members. Eight machine guns in the nose and one in a rear turret. Besides its main mission, the G.1 could be configured for ground attack and light bombing missions. The design and construction of the prototype (registered as X-2) was completed in just *seven months*.

"The G.1 prototype, powered by 650 hp Hispano-Suiza 14AB-02/03 engines, had its first flight at Welschap Airfield, near Eindhoven on 16 March **1937** with *Karel Toman-Mares* at the controls. Later, *Emil Meinecke* took over much of the test flights. The maiden flight went well, but a subsequent test flight in September 1937

ended with a supercharger explosion that nearly caused the loss of the prototype. The accident prompted a replacement of the Hispano-Suiza engines with 750 hp Pratt & Whitney SB4-G Twin Wasp Junior engines.

“Besides the Dutch *Luchtvaartafdeeling*, several foreign air forces showed an interest in the G.1. as either a fighter or dive-bomber. In order to test its potential as a dive-bomber, the G.1 prototype was fitted with hydraulically operated dive brakes under the wings. Flight tests revealed that the G.1 was capable of diving at over 644 km/h and demonstrated aerobatic capabilities. Orders for G.1-b Wasp aircraft came from Spain (26 ordered) and Sweden (18). The Dutch *Luchtvaartafdeeling* ordered 36 G.1-a’s with 725 hp Bristol Mercury VIII engines, the standard engine used by the Dutch Air Force, in order to equip two squadrons.



**The Fokker G.1-a, the pride of Dutch air defense and all boy/airplane enthusiasts in 1940 [29]**

“In 1940, during the lead-up to hostilities, a total of 26 G.1-a’s were operational in the 3rd Jachtvliegtuigafdeling (JaVA) at Rotterdam (Waalhaven Airfield), and 4th JaVA Fighter Group at Bergen near Alkmaar. On 10 May 1940, when Nazi Germany invaded the Netherlands, 23 G.1-a aircraft were serviceable. The German invasion started with an early morning (03:50 hours) Luftwaffe attack on the Dutch airfields. While the 4th JaVA received a devastating blow, losing all but one of its aircraft, at least two 3rd JaVA G.1-a fighters were launched in time to down three of the Heinkel He 111 bombers. The two squadrons continued to fly, but with mounting losses, bringing their numbers down to *three airworthy aircraft by the end of the first day*.

“... In the “Five-day War” that followed May 10, the available G.1 fighters were mainly deployed in ground attack missions, strafing advancing German infantry units, but also used to attack Junkers Ju 52/3m transports.

“... G.1 fighters were employed over *Rotterdam* and *the Hague*, contributing to the loss of 167 Ju 52s, scoring up to 14 confirmed kills. (The majority of the Ju 52s were shot down by very effective anti aircraft artillery.) At the conclusion of the hostilities a score of valiant people had died, ardent fighters by personality or disposition, as well as others who had found themselves *nolens volens* in the midst of a foul war of aggression. Several G.1 airplanes were captured by the Germans and later used for training purposes.

“On 5 May 1941, a Fokker test pilot, *Hidde Leegstra*, accompanied by engineer *ir. Piet Vos*, (a Fokker director), managed to fly a G.1 to England. The crew's subterfuge involved acquiring additional fuel for the supposed test flight as well as ducking into clouds to avoid the trailing Luftwaffe aircraft. After landing in England, the G.1 was conscripted by Miles Aircraft Company for study and testing. There are no surviving G.1s today, although a replica can be found in the depot of the new Nationaal Militair Museum (NMM) at Soesterberg.” [30]

## 12. Frederick (Frits) Koolhoven

---

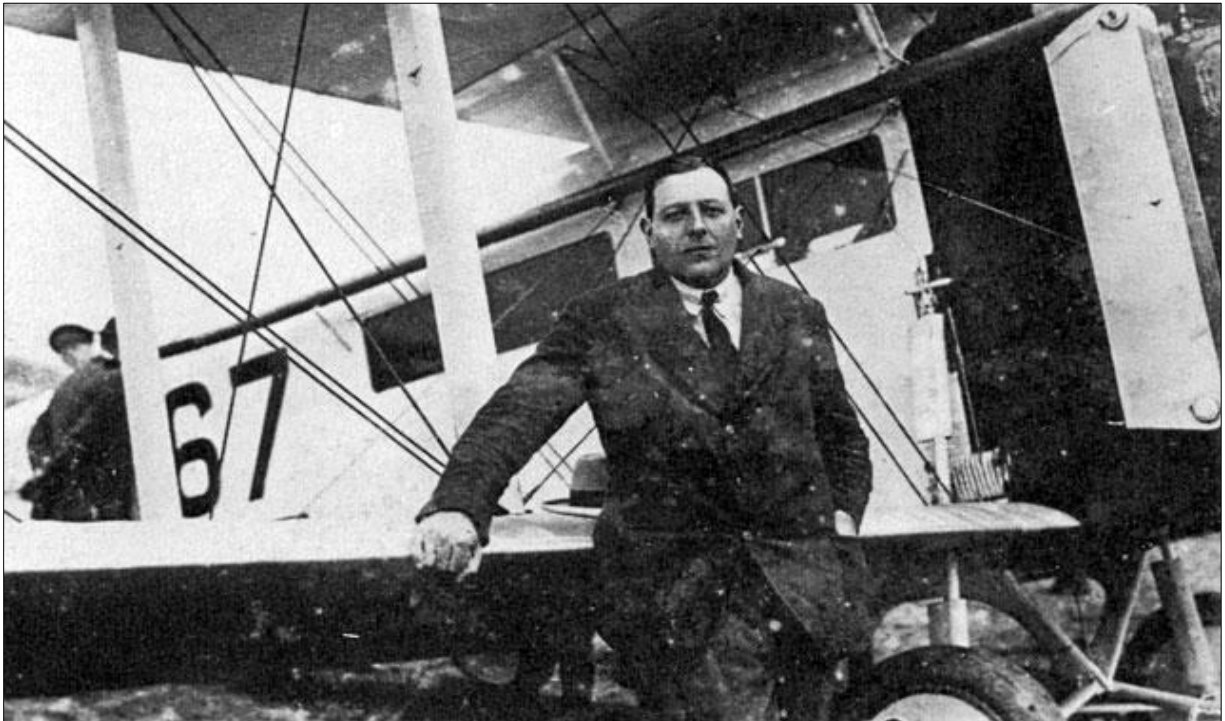

**Frits Koolhoven in front of the B.A.T.'s F.K.26 biplane of his design in 1919**

**This bi-plane for 4 passengers was one of the first, if not *the* first post-war commercial airplane, with an exceptionally roomy passenger cabin.**

25

**Frederick (Frits) Koolhoven** (11 January 1886 – 1 July 1946) was an aircraft designer in Britain and later in his native Netherlands. He was born in [Bloemendaal, Netherlands](#). After training as an engineer in [Liège](#) and [Antwerp](#), he worked from 1907 as a mechanical engineer for the automobile factory [Minerva](#) in Antwerp, and also drove in races and rallies for them. He became interested in aviation. In **1910** he acquired his own [Hanriot](#) aircraft, and was involved in the construction of the first Dutch plane, the "[Heidevogel](#)"

He designed many aircraft, initially in England from **1912** for [British Deperdussin](#), then from 1914 for [Armstrong Whitworth Aircraft](#), then from **1917** as chief designer for the [British Aerial Transport Co. \(B.A.T.\)](#) alongside the Dutch chief draftsman [Robert B.C. Noorduy](#)n. He returned to the Netherlands, but there the market was dominated by [Fokker](#), so he returned to his old job as an automobile engineer for the [Spyker](#) automobile factory.

In **1921**, a group of businessmen founded the [Nationale Vliegtuig Industrie](#) (N.V.I. - "National Aircraft Industry Inc."), and hired him as their chief designer. The company lasted only four years. As with BAT, N.V.I. turned out many technically advanced designs, which attracted attention from all over the world, but received virtually no orders. At the demise of N.V.I., [Koolhoven](#) convinced several shareholders that the company would still have been viable if he had had complete control of the operations. So when N.V.I. was dissolved, its assets were taken over by a new company: [N.V. Koolhoven Vliegtuigen](#) ("Koolhoven Aircraft Inc.").

The company became the second aircraft manufacturing company in the Netherlands after Fokker, but the factory at [Waalhaven](#) was destroyed by German bombing in the Blitzkrieg on 10 May **1940** at the outbreak of World War II. Koolhoven was convinced that the bombing had everything to do with his contribution as an aircraft designer in England during World War I. For unknown reasons he became a (inactive) member of the [Nazi Movement in the Netherlands](#) (NSB). Because of his membership he was interned by the Dutch police after the war, but was released after a few days. Frits Koolhoven died of a stroke at Haarlem in **1946**.<sup>[31]</sup>

## 13. Erich Schatzki's Flight; Work at N.V. KOOLHOVEN, Rotterdam



**Koolhoven FK.58 (1938) design by Erich Schatzki [32]**

On Feb 18 1938 the Dutch daily newspaper *Maasbode* announced that *Erich Schatzki* had left the Fokker company and joined the *N.V. Koolhoven Vliegtuigen* in Rotterdam because of a disagreement with Fokker's vice director *ir E.J.(Jacob) van Tijen*, who had succeeded *ir. Stephan* in November 1935. According to Schatzki van Tijen allowed him too little freedom of action. At the suggestion of a good friend he joined the *Koolhoven Company*. In Rotterdam. Erich Schatzki found himself in a completely different atmosphere. Also, building airplanes in those days was completely different from today, as he remembered later:

*"Frits Koolhoven* was a peculiar fellow, but I worked for him with great pleasure", reminisced Erich Schatzki in 1966. "One day he assembled his staff. The situation was not very good, because the Spanish Civil War had finished, sales had stopped and the stock had piled up. Frits told us the French government had asked him to build the fastest and best armed Fighter ever... This is our chance, he said, it has to be finished in four months! I thought that he was crazy, because I came from a normal business environment. But F.K. had a tremendous team of skilled people. Two and a half months after the first drawing was made the machine was ready! Super modern, with retractable landing gear!"<sup>[33]</sup>



It was in **1938**, at the request of the French government, that *N.V. Koolhoven Vliegtuigen* designed in a very short time a modern fighter, the FK.58. The work was really done under supervision of *Erich Schatzki*, who had left Fokker after some disagreements with Fokker's management. The new plane followed the lines of de Fokker D.XXI very closely and had like that machine a wooden (mid-)wing and a welded steel tube fuselage covered by aluminum sheet and linen. Koolhoven's machine was somewhat heavier and faster than the Fokker D.XXI because it had retractable landing gear. After the machine was tested in July 1938, the French government ordered fifty with French radial engines for delivery in early **1939**. As the Dutch air force also ordered a total of 36 machines with British radials, Koolhoven had to subcontract production to *SABCA* in Belgium and to a French factory in Nevers.

In France, the 13 fighters operational by May **1940** were manned by expatriate Polish pilots of Captain *Jasionkowski's* patrouille DAT (Défense Aérienne du Territoire) based at Salon. As delivered, the fighters were not armed and the Poles had to acquire machine guns and fit them. From 30 May 1940, they were used in the defense of French cities, patrolling in Avignon -Marseille area; the type's service life was short-lived with only 47 or so operational sorties recorded. After the fall of France, all surviving airframes were scrapped. [<sup>34</sup>]

**TABLE I**

	year	wing span m	wing area m <sup>2</sup>	sleek ness	Wight empty kg	wght maxTO kg	wght ratio	wing load kg/m <sup>2</sup>	power hp	power load kg/hp	speed max km/h	speed at m	speed cruise km/h	range km	ceiling m
<b>D.XXI</b>	1935	11.0	16.2	7.5	1594	1970	1.24	122	830	2.4	460		429	930	11350
<b>G.1</b>	1937	17.2	38.3	7.7	3325	5000	1.50	131	1660	3.0	475	4100		1510	10000
<b>FK.58</b>	1938	11.0	17.3	7.0	1930	2750	1.42	159	1030	2.7	505		450	750	10000
<b>Bf-109</b>															
<b>E1</b>	1939	9.9	16.1	6.1	2010	2505	1.25	156	1085	2.3	570	3700		850	10500
<b>P.47D</b>	1943	12.4	27.9	5.5	4535	7940	1.75	285	2600	3.1	713	8840		1300	13100

**Data of fighters that Erich Schatzki worked on, with exception of the *Bf-109* (shown for comparison only)**

When *Erich Schatzki* was in The Netherlands, he worked on three fighter airplanes (see three top lines in Table I). The first (Fokker D.XXI) and third (Koolhoven FK.58) planes were in fact very similar, the FK.58 somewhat heavier and also more powerful with its Gnome Rhône 14N-16 1000 hp engine. Its top speed was approximately 10% higher than the D.XXI, in all likelihood because of its retractable landing gear. The gear folded, curiously, partly into the sides of the rump. The frontal view of the aircraft is very pleasing (see previous page).



**The adversary: Messerschmitt Bf 109-E3 (1940) [in Swiss museum, Wiki]**

The FK.58 however, would be outmaneuvered in aerial combat by the Messerschmitt 109, which had a smaller wing, slightly more powerful engine and a better aerodynamic shape, resulting in a remarkable top speed of 570 km/h. It was in many respects a more highly developed piece of technology. [35] [36]

Later in his career *Schatzki* would be working on the *Republic P.47 Thunderbolt*, which may well be considered the ultimate propeller driven heavy fighter (see bottom entry in Table 1).

## 1940/1941: Farewell To Old Friend

On May 10, 1940 Nazi Germany executed a brutal invasion of the Netherlands. In the following five days the Dutch fought valiantly against the superior forces on land and in the air. Rotterdam was bombed indiscriminately and the Koolhoven aircraft factory plus aerodrome Waalhaven were destroyed.

*Erich Schatzki* found refuge (in the south of the country?) and, after the Dutch surrender, went to work designing machinery for a tobacco company (Philip Morris in Eindhoven?).



**Carl August Freiherr von Gablenz (1893-1942)**

*Carl August Von Gablenz visited personally the Netherlands to warn his old friend Erich Schatzki that Jews would not be safe during the German occupation of the Netherlands. Taking the warning seriously, and with the help of his friend, Schatzki departed once more, with his family, to Spain. From there the Schatzki family made the arduous 7000 km trip by steam ship to the United States via Cuba. In the United States Erich Schatzki was hired by Republic Aviation of Long island – builders of fighters for the US air force.*

As of November 1 1941, the Secretary of the Reichsluftfahrtministerium and Generalinspektor *Erhard Milch* appointed *August Carl von Gablenz* to Head of Planning for the Luftwaffe. He became a Major General and the first reserve officer of the First World War to be appointed to general. At the same time he became one of the bureau chiefs of the Reichsluftfahrtministerium. Ten months later, on August 21 1942, he crashed on an official mission with a French-built Siebel Si-204 liaison-airplane near Mühlberg/Elbe. Two co-passengers and he died. The cause of death of one of the most experienced and famous Lufthansa captains of the time has never been explained satisfactorily.



## 14. The Seversky Aircraft Company

---



### **Alexander P. de Seversky embraced by his SEV-3XAR (1934)**

Quotation from a delightful book by another Russian ex-patriot, Boris Sergievsky: <sup>[37]</sup>

...*Alexander P. de Seversky* became famous early. Returning from his first combat sortie as an Imperial Russian aviator in **1915**, he lost his left leg below the knee when a hung-up bomb destroyed his plane on landing. Undaunted he returned to combat flying a year later and had claimed thirteen victories when his right leg was shattered in a motorcycle crash. His government sent the personable young hero to Washington as air attaché in **1917**. When the Bolsheviks seized the Russian government, he stayed on in the USA, changing his surname from Prokofiev-Seversky to *de Seversky*. His test-piloting skills earned him a commission as a major in the U.S. Air Service a few years later, even though he had not yet become an American citizen.

By **1930** de Seversky was a well-known test pilot – one of ten certified to fly *Sikorsky* aircraft by the builder's insurance company, along with *Boris Sergievsky*, *Charles Lindbergh* and racing pilot *Frank Hawks*. He was trying to start his own company and wrote Boris Sergievsky from Palm Beach that he was delighted by Boris' record-breaking flights: "People keep congratulating me on them, and it helps my promotion. Keep it up! [<sup>\*</sup>]"

De Seversky soon began breaking records himself. In **1931** he launched his own aircraft company, producing a beautifully streamlined all-metal monoplane, the SEV-3. This airplane was designed by yet another émigré of the Russian Empire, *Alexander ('Sasha') Kartveli* (born Kartvelichvili), who had come to the USA from France in 1927. (Though de Seversky was full of creative ideas, he needed an experienced designer to put them into practice.) Making the most of his meager resources, de Seversky modified his aircraft several times to meet the needs of various customers. The U.S. Army Air Corps bought the two-place version as the



de Seversky BT-8 trainer (1938) [photo source; Wiki]

BT-8 trainer in **1935**, and a later, more powerful single-seater variant, as the P-35 fighter in **1936**. These were the first all-metal, cantilever monoplane trainers and fighters purchased by the Air Corps.

De Seversky was looking for more orders in Europe early in **1939**, when his company's board of directors fired him, citing his reckless spending. (According to a 1939 employee [<sup>†</sup>] de Seversky had outraged Army Air Corps leaders by selling twenty export fighters in South America, complete with engines and instruments provided and paid for by the American government, and the Air Corps generals demanded his ouster.)

---

\* The New Yorker, nov 9, 1940, 13

† Ralph Alex, Sikorsky symposium II, June 25, 1994

## 1939 Exit Seversky; start of Republic Aviation

On October 13 **1939** the Seversky Aircraft Corporation of Farmingdale, L I., N.Y., U.S.A., changed its name to *Republic Aviation Corporation*. The adoption of the new name was voted at a stockholders' meeting and Mr. W. Wallace Kellett, President of the Corporation, explained that the revision of the name was the only change contemplated in the organization. At the same time it was announced that Mr. Alexander P. de Seversky was no longer connected with the company in an executive capacity.

World War II was coming and the United States needed *Alexander Kartveli's* promising designs produced, but not with de Seversky at the company's helm. The company, renamed *Republic Aviation*, produced 15,000 of Kartveli's P-47 Thunderbolt fighters in World War II and his later fighter designs, the F-84 and the F-105 served the Air Force well for the next thirty years.

De Seversky found a new career, writing and lecturing on the need for a powerful air arm. His bestselling **1942** book *Victory through Air Power* and an animated film version he made with Walt Disney persuaded millions of Americans that air superiority was the key to victory. He won the prestigious Harmon Trophy in 1939 for his advanced aircraft design and he won it again in **1947** for his tireless promotion of air power.

*Alexander P. de Seversky* died on August 24, **1974**, aged 80 at New York City.



Alexander P. de Seversky, author on strategic air war (1942)

## 15. Alexander Kartveli At Republic Aviation Co.

---



Alexander Kartveli 1897-1974

In **1939**, Alexander P. de Seversky was removed as head of his company and the Republic Aviation Corporation was born. The first major aircraft to emerge from the new company was the P-47, using a new innovative design of Alexander Kartveli. Two concept designs, named XP-44 and XP-47, were developed first but dropped as they did not meet the requirements of the Air Corps. According to records, Kartveli was called in from the Experimental Aircraft Division of the USAAC and informed about the prototypes being cancelled.

During his return to New York by train, he took a sheet of paper and drew a completely new design. The new aircraft was intended to break the back of the German Luftwaffe. The famous *P-47 Thunderbolt* with its robust characteristics was born. Despite some initial flaws, the heavily armed and armored aircraft was improved during a continuing period all through the war and it achieved more than Kartveli had ever hoped for. The U.S. entry into the war in December **1941** rapidly increased the need for the XP-47B and work on the plane progressed quickly. In June **1942**, the Army took delivery of its first P-47Bs. They soon

placed an order that required Republic Aviation to quadruple the size of their factory and build three new runways at the Farmingdale, New York factory. Eventually this proved inadequate, and in November **1942**, the Army authorized the construction of a new factory adjacent to the Evansville, Indiana airport.

Throughout the war, the P-47 would undergo constant development. The final version of the P-47 would be the P-47N, a long-range version with longer wings and fuselage, and an increased fuel capacity. The P-47N was designed to escort B-29s on long missions to Japan for a planned invasion of the Japanese homeland that never came. Production of all versions ended in November **1945**. By then, 15,660 P-47s had been built.

At the end of the war Kartveli designed a sleek 'flying photo lab' called the *Republic XF-12*. Initially planned as a four-engine postwar transport, American Airlines canceled its orders and only two prototypes were built for the US Air Force. At the same time a new concept of fighter with turbojet engine would emerge. The *F-84 Thunderjet*, which Kartveli had already developed in **1944**, was going into serial production in **1946**. Soon the swept-wing variant *Republic F-84F Thunderstreak* was added. A total of 10,000 of these new generation aircraft would be constructed.

Later on, he would lead the team that developed the *F-105 Thunderchief*. At the same time he was heavily involved with a 1960s-era Air Force project called the 'Aerospaceplane', an orbital logistics vehicle a decade before NASA started development of its Space Shuttle. The radical turbo ramjet-powered *XF-103* was another Kartveli design, It remained stillborn because the propulsion community was unable to produce a suitable engine to power the Mach 3 interceptor.

Alexander Kartveli contributed significantly to the science of flight and the readiness of the US military. He was the leader of the design of a multitude of projects, which eventually ended with the *A-10 Thunderbolt*, now built by Fairchild.

Alexander Kartveli died of unknown causes in **1974** in New York.

## Clippings from the Web:

### Alexander Kartveli Retires

*FLIGHT International, 7 June 1962*

...Russian-born *Alexander Kartveli*, who has been vice-president, research and development, of Republic Aviation Corporation since 1956, retired on June 1 but is continuing as consultant to the company. He is one of its original members, having joined in 1931 when it was known as Seversky Aircraft Corporation (the name was changed in 1939). Aircraft developed by Kartveli and his design team have included the P-47, F-84, and F-105D. He went to the US in 1927, after working in the French aircraft industry. Two years later he joined the Fokker Aircraft Co and in 1931 became assistant chief engineer of Seversky Aircraft Corporation, pursuing his conviction that all-metal airplanes would be the aircraft of the future.

Republic's president, *Mr. Mundy I. Peale*, has said of him: "*Sacha Kartveli* is one of the true aeronautical geniuses and Republic can ill afford to lose his creative talents."...

### A Book Review, *FLIGHT International, 25 June 1964*

...The author of the P-47 biography has culled reminiscences from former pilots and from the files of Republic Aviation Corporation. Thus, a Lt-Col C. S. Hough is recorded as having exceeded 780 m.p.h. in a Thunderbolt, in a dive from 39,000 to 18,000ft, while serving in England in the USAAF during the war; the paper tanks made by Bowater-Lloyd, which gave the aircraft an extra 110 gallons of fuel for European operations, are recalled; and of Alexander Kartveli the author writes that although his post-war designs involved far more drawing-board work than anything he did prior to 1946 (the P-47 was initially sketched on the back of an envelope), he earned his place in air history simply by being "the man who designed the Jug."...

*The P-47 Thunderbolt, by Len Morgan, (Morgan Aviation Books, Box 20141, Dallas, Texas 75220;*



The Jug

## 16. 1943-1958 Erich Schatzki's Work for Republic and Israel

In **1941** *Erich Schatzki* was personally warned by *Freiherr von Gablenz* that, being Jews, he and his family risked to be deported from occupied The Netherlands to a concentration camp. Von Gablenz helped Schatzki and his family escape via France and Spain to the United States. In 1943 the Schatzki family settled in the New York area and Erich found work as a chief design engineer with *Republic Aviation* on Long Island. Republic was at that time busily employed with the manufacturing and continuing development of the U.S. Air Force's most famous fighter, the *P-47 Thunderbolt* and Schatzki's design experience with European fighter planes was directly applicable.



Dr. Erich Schatzki (Foto aus der Zeitschrift „ötv-Standpunkte“)

### Republic P-47D Thunderbolt (1943?)

Jet engines became available during World War II and General Electric became the main supplier. The first American jet fighter was the *Lockheed Shooting Star*, which had straight wings and a GE engine which entered production as the *Allison J35*. In **1946**, Republic turned its attention to adapting its own fighter design to the new engine and obtaining new military contracts. It developed a single-engine jet airplane to meet an Army requirement for a fighter with a top speed of 600 mph (970 km/h). The first (straight wing) *YP-84A Thunderjet* flew on February 28, 1946, but the aircraft was plagued with so many developmental problems that the first improved *F-84B* didn't enter Air Force service until **1949**. In the end, it was the *F-84D* version that would go on to become an important aircraft during the Korean War (1950-1953), flying 86,408 missions.

Erich Schatzki became very knowledgeable on the subject of jet engines and made some very interesting contributions to their use. For one he developed a kind of auxiliary engine pod for *jet assisted take-off*. He also applied for a patent on *thrust reversers* (**1953**) to slow down a jet aircraft effectively after touch down. The jet assisted take-off system was employed on the Israeli *El Al* cargo planes, the Curtiss C-46.



A bomb-laden U.S. Air Force Republic F-84E-15-RE *Thunderjet* from the 9th Fighter-Bomber Squadron, 49th Fighter-Bomber Wing/Group, taking off for a mission in Korea. This particular aircraft was shot down by flak on 29 August 1952. [source: Wiki]

In 1945 an American intelligence mission discovered in *Braunschweig* (occupied Germany) the secretly developed *Pfeilflügel* (arrow- or swept wing) for transonic speed. In 1947, after a short stay in Great Britain, its inventor, *Dr. Adolf Busemann*, was persuaded to come to the US as part of 'Operation Paperclip'[\*]. After his arrival the use of *swept wings* became the fashion for US high speed airplanes. In fact, that same year the first American warplane with swept wings, the *Boeing B-47 Stratojet*, took its first flight. In 1949, a swept-wing version of the *Thunderjet*, the *F-84F Thunderstreak*, was ready, but additional development and engine problems delayed the aircraft from entering active service until 1954.

***By this time (1949) Erich Schatzki had taken leave of Republic to visit Israel, the newly formed Jewish State.***

It is interesting to know that, while at Republic on Long Island, Schatzki had been teaching aeronautical engineering at the *Brooklyn Polytechnic Institute* from 1948-1949. From that time dates this remarkable testimony that can be found on the web:

**ca. 1949** "...Peter B. Lederman, an only child, born [in 1931] in Weimar, Germany. His father was an accountant who spent a week in a concentration camp but was recalled in order to help the State collect taxes. When Peter was seven

---

\* Dr. Busemann worked first at NACA Langley. In 1963 he became a professor at the U. of Colorado in Boulder, where he died in 1986.

the family fled to the United States, spending about six months in England on the way. They settled in New York City; eventually Lederman chose to attend the Forest Hills High School, where he was inspired in science by his chemistry and biology teacher, Paul Brandwein. Advised **by Eric Schatzki**, a chief engineer at Republic Aviation, he abandoned his desire to study aeronautical engineering [?!] and instead chose as his major chemical engineering when he entered the University of Michigan.... “[<sup>38</sup>]

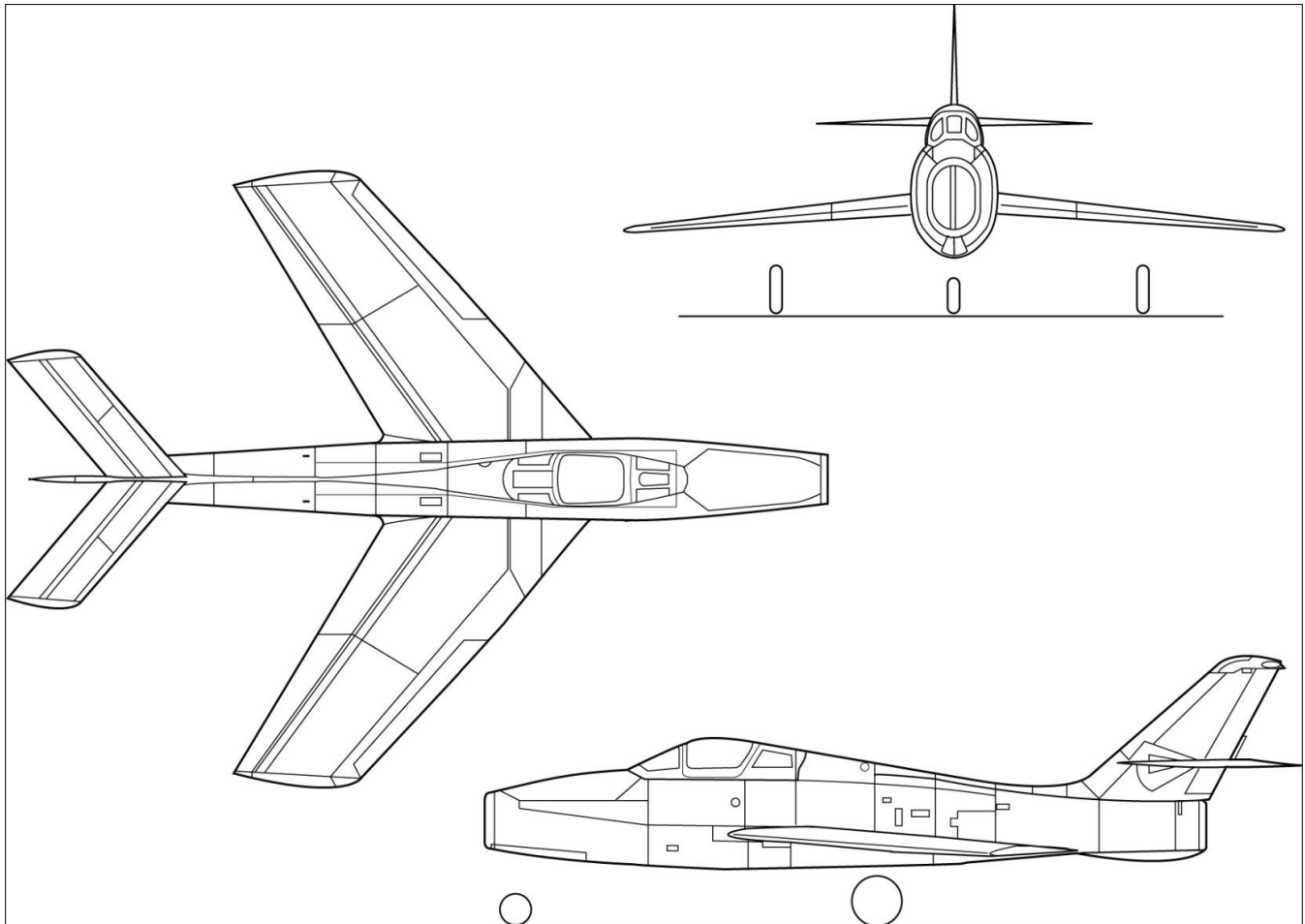

**Republic F-84F Thunderstreak (swept wing design 1949; operational ca. 1954 - source: Wiki)**

It is not quite clear at what time exactly *Erich Schatzki* took leave of Republic Aviation to visit Israel. It must have been at some time in **1949**, one year after the founding of the state, because there is evidence that he assisted in the formation and initial organization of *El Al Airlines* in that country. He apparently also functioned as a Chief Engineer for the fledgling Israeli Air Force, before he returned to the USA in **1950**.<sup>39</sup>

*Erich Schatzki* worked at Republic Aviation until **1953** when he established himself as an independent aeronautical design and development consultant (*Schatzki Engineering Co*). [\*] Having become very knowledgeable on the subject of *jet engines*, Schatzki applied for several patents on that subject in that year. He worked among others for *El Al in Israel* as becomes clear from the following quotations in the aviation press (see next pages). [<sup>40</sup>] In **1956** followed the announcement of the election of *Erich Schatzki* as president and member of the board of the *Liberty Products Corporation*, a 23 year old aircraft parts *manufacturer* of precision components such as frames, rudders, flaps, etc. at Farmingdale Long Island. [<sup>41</sup>] Liberty Products Corp. was a subsidiary of *Penn-Texas* which itself was a starting conglomerate that also included the *Colt Arms* factory and the *Pratt & Whitney Machine Tool* company (not to be confused with the P&W engine company).

---

\* At that same time, in Israel, the Ministry of Defense formed *Bedek Aviation Company*, later *Israel Aircraft Industries (IAI)* to maintain Israeli Air Force planes.

## 17. 1953-1958 USA: Schatzki Engineering Co

---

FROM THE PRESS:

### 208 FLIGHT 1953 CIVIL AVIATION: MARBORES FOR EL AL

FURTHER details are announced by El Al Israel Airlines of their plan to equip each of their C-46 Commandos with two Turbomeca Marbore II auxiliary jets beneath the fuselage. The installation was designed by *Dr. E. Schatzki*, a former Lufthansa pilot and engineer who emigrated to the United States before the war and spent some years with the Republic Aviation Corporation.

The Marbore develops a static thrust of 880 lb and has a dry weight of 290 lb. The streamlined pod developed for El Al weighs 425 lb and embodies "eyelid" doors which are closed when the jet is not in action. The two pods are attached to the Commando's fuselage, approximately at the e.g. position, by a three-bolt connection; they are interchangeable and can be replaced in 20 minutes. The two supporting members are enclosed in a fairing which also contains electrical, fuel and fire-extinguishing connections. El Al's auxiliary jets will use ordinary 100/130 octane fuel from the existing system. The Marbore's fuel consumption, incidentally, is quoted at 170 gallons per hour at take-off and 133 gallons per hour at maximum continuous power.

The addition of the jet units entails practically no structural reinforcement of the Commando and only a small number of minor modifications, including the installation of three instruments serving both units and indicating r.p.m., oil-pressure and -temperature, and jet-pipe temperature. A firewall will be inserted between the fuselage and the pod, and the existing de-icing system will be extended to protect the air intake.

*Dr. Schatzki* suggests that installation of two Marbores may be the most promising solution yet offered to the American operators' twin problem of flying the C-46 at a more economical all-up weight than the 45,300 lb permitted at present and of meeting new C.A.A. performance requirements by December 31<sup>st</sup> next. He claims that the extra thrust provided by the Marbores enables the C-46 to take-off 10,000 lb heavier without any loss of performance. It is estimated that the take-off performance of El Al's boosted Commandos at 50,000 lb will be comparable to that of a standard C-46 at a gross weight of only 40,000 lb. Automatic controls are provided to prevent the Marbore's from over-heating or over-speeding in flight.

37

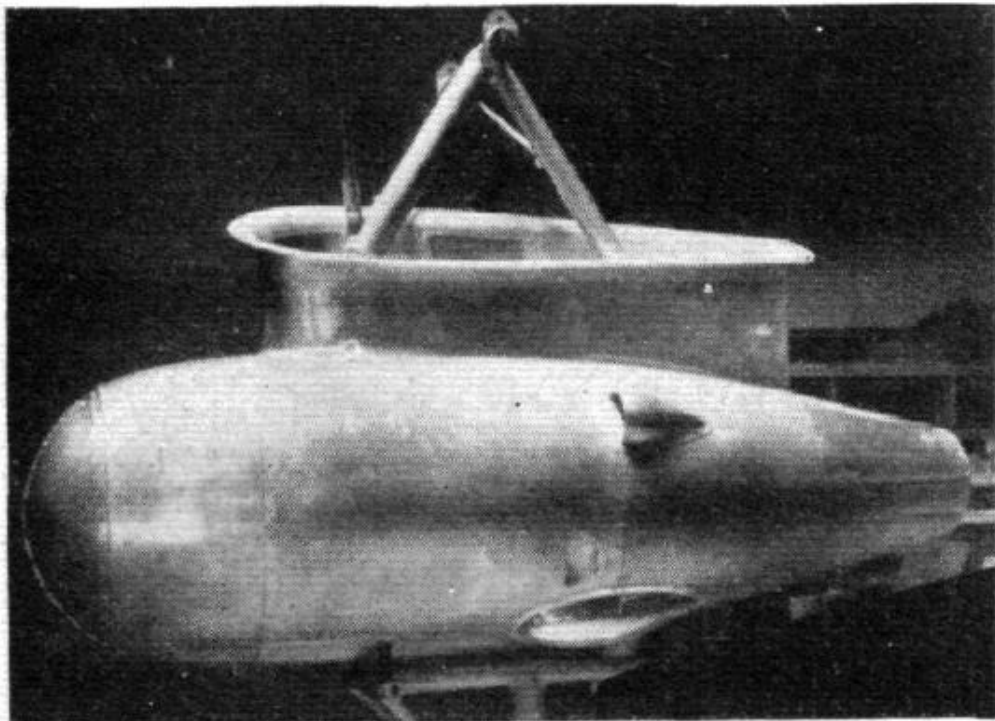

**BOOSTER:** Two of these pods, each containing an 880 lb thrust Marboré turbojet, will—as reported in the adjacent paragraph—be slung beneath El Al's C-46s to improve take-off performance.

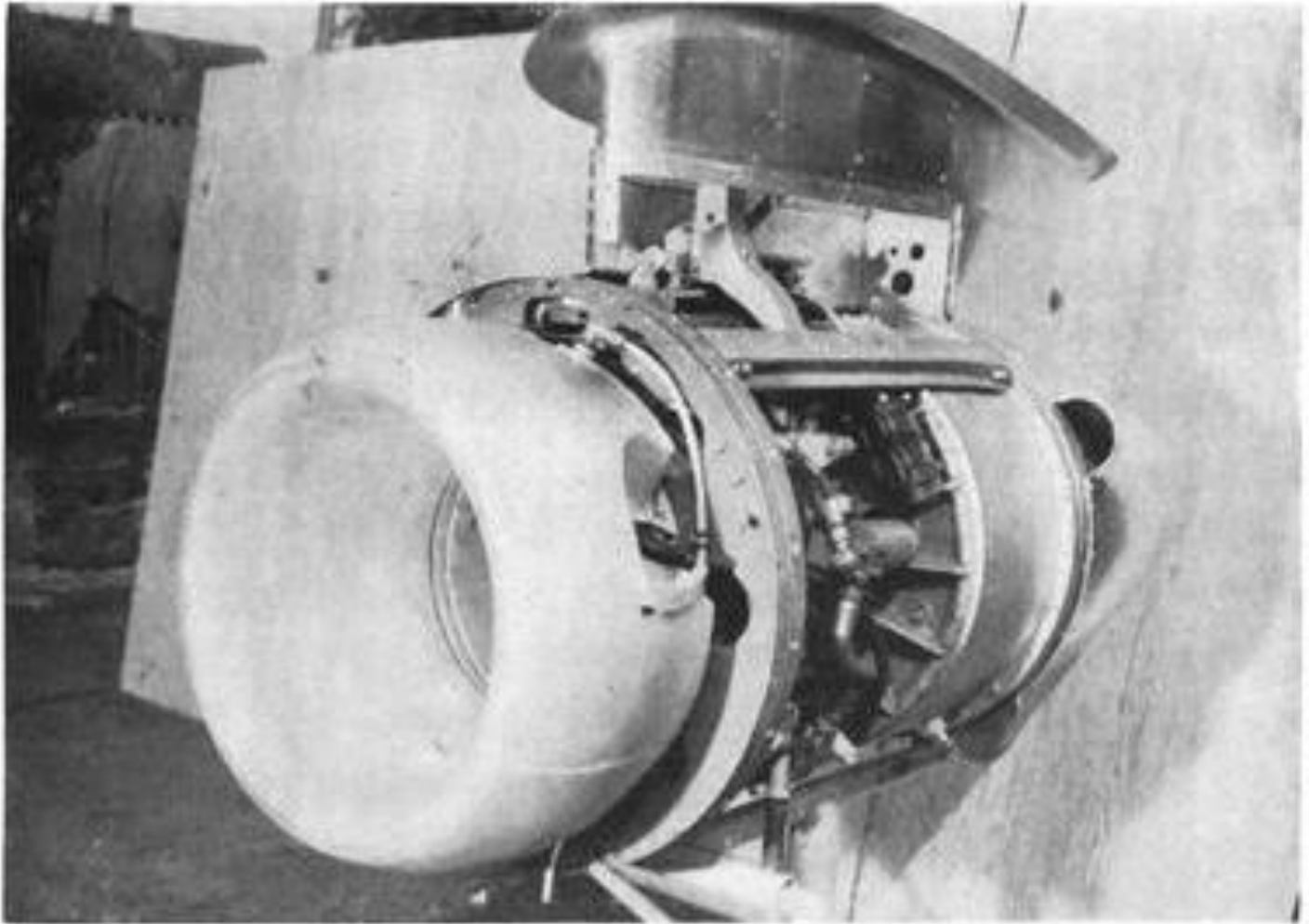

## Auxiliary Jet Pod Details

The auxiliary powerpack developed for El Al Israel Airlines by consultant Erich Schatzki is seen with all of its cowling removed. The engine is a Turbomeca Marbore jet giving 880 lb. thrust. Circular nose-piece serves the three-fold purpose of oil

tank, oil cooler and venturi. El Al plans to run tests of the Marbore as an auxiliary power unit on a C-46 Commando (Aviation Week Aug. 10, p. 38). Price of the complete powerpack is estimated at \$25,000 ready to install.

AVIATION WEEK, January 25, 1954

### FOLLOWING PAGE:

MECHANISM FOR CONTROLLING RELATIVELY HIGH VELOCITY FLOW OF FLUIDS LONGITUDINALLY THROUGH AND Laterally FROM AMBULANT CONDUIT MEANS

Erich Schatzki, 68--37 Yellowstone Blvd.,  
Forest Hills, N. Y.

Filed **Aug. 12, 1953**, Ser. No. 373,724

20 Claims. (Cl. 60--35.54)

This invention relates to improvements in jet propelled a/c - thrust reversal

Oct. 3, 1961

E. SCHATZKI

3,002,342

MECHANISM FOR CONTROLLING RELATIVELY HIGH VELOCITY  
FLOW OF FLUIDS LONGITUDINALLY THROUGH AND  
LATERALLY FROM AMBULANT CONDUIT MEANS

Filed Aug. 12, 1953

5 Sheets-Sheet 4

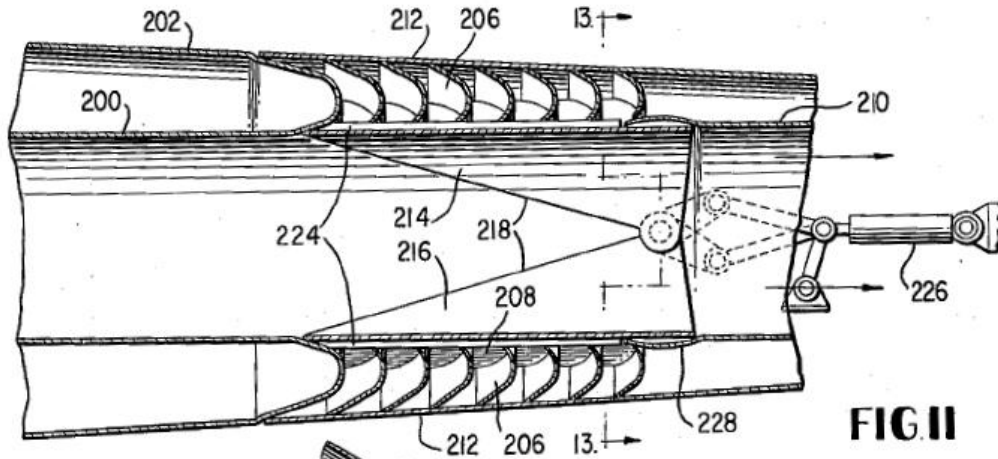

FIG. 11

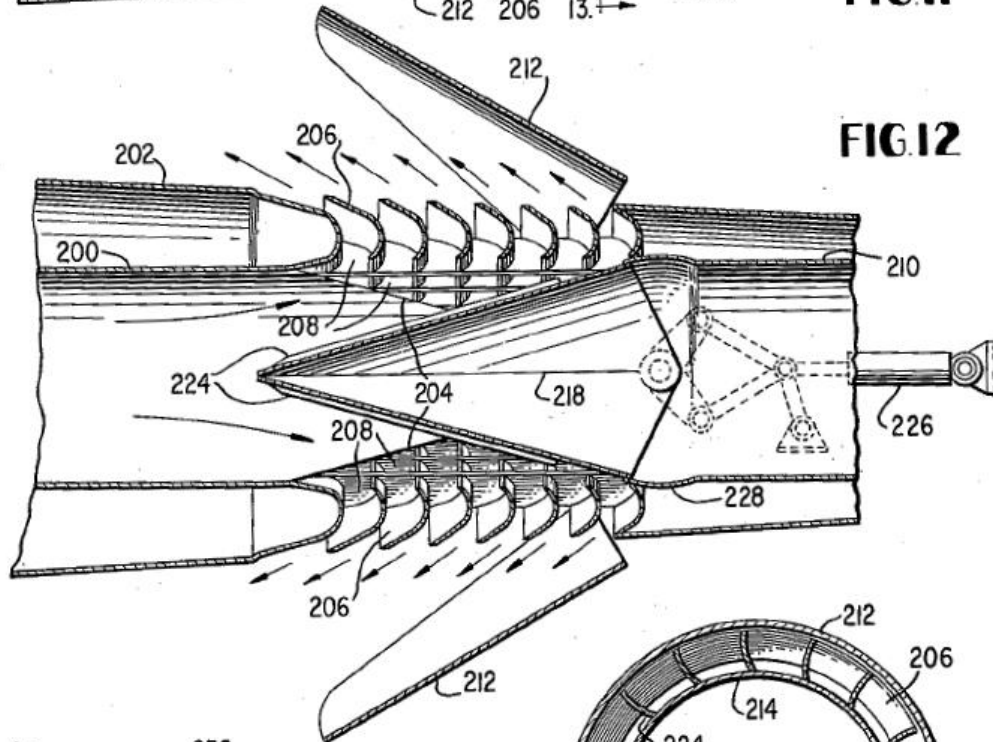

FIG. 12

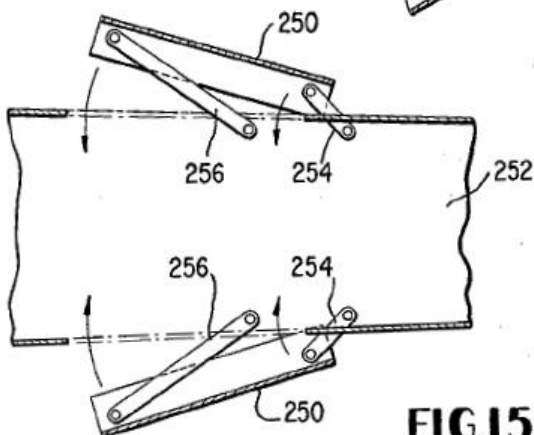

FIG. 15

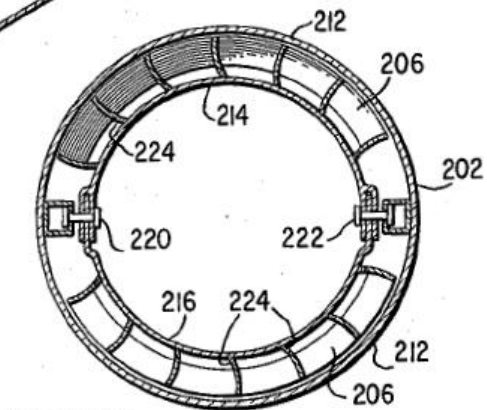

FIG. 13

INVENTOR.  
ERICH SCHATZKI

BY

Watson Leavitt & Kelton  
ATTORNEYS

## 18. 1951: Al Schwimmer: Israel Aircraft Industries

---



**Al Schwimmer 1917-2011**

*Al Schwimmer* was born in **New York** in **1917** to Jewish parents who had emigrated to the United States from Eastern Europe. He never used his given birth name of Adolph, preferring the nickname “Al”. In **1939**, Schwimmer began his aerospace career at *Lockheed Corporation* as an engineer and also received his civilian pilot license.

During **World War II**, he worked for *TWA* and assisted the U.S. Air Transport Command as a flight engineer. During **Israel’s War of Independence (1948)**, Schwimmer used his World War II experience and his contacts to smuggle surplus war planes to Israel as that fledgling state battled against the invading armies of its neighbors. Using circuitous routes, he also recruited the pilots and crews to fly the planes to Israel. Many of these men became the nucleus of the *Israeli Air Force*.

In **1949**, *Al Schwimmer* returned to the United States and, in **1950**, he was convicted in the United States of violating the **US Neutrality Acts** for smuggling the planes into Israel. Schwimmer was stripped of his voting rights and veteran benefits and fined \$10,000, but did not receive a prison sentence. Schwimmer refused to ask for a pardon, believing that smuggling weapons to help create a Jewish State was the right moral decision to make, and that breaking the law was a proper form of moral civil disobedience. In 2001 President **Bill Clinton** gave Schwimmer a presidential pardon.

In the early **1950s**, Schwimmer, who was running an aircraft maintenance company in **Burbank, California**, was approached by *David Ben-Gurion*, Israel’s then prime minister, who asked Al Schwimmer to return to Israel and establish an aircraft company for commercial and military purposes. Schwimmer acceded to Ben Gurion’s request and founded **Israel Aircraft Industries\***, of which he became the first CEO.

Al Schwimmer was one of the founders of *Savyon*, but later moved to **Tel Aviv**. In the mid-1980s, Schwimmer was a special adviser for technology and industry to Israel’s then-Prime Minister *Shimon Peres*, who became a close friend.

*Al Schwimmer* died in **2011**, on his 94th birthday in **Ramat Gan**.<sup>[42]</sup>

---

\* I.A.I. was founded in **1953** as Bedek Aviation Company under the initiative of *Shimon Peres*, then director general of the Ministry of Defense, in order to maintain Israel Defense Forces aircraft. The company originally had 70 employees. By 2013 it is known as *Israel Aerospace Industries* and has 16,000 employees.

## 19. 1958-1962: Erich Schatzki's Work In Israel



FULL-SCALE MOCKUP of Israeli B-101C executive transport shows T-tail layout of empennage. A V-tail was part of earlier design.

April 10, 1961 Aviation Week and Space Technology

41

It is likely that it was *Al Schwimmer* who asked *Erich Schatzki* to join *Israel Aircraft Industries* at Tel Aviv. In **1958** the fledgling company was mainly engaged in the maintenance of a great variety of different aircraft and engines that were employed by *El Al Airlines* and the *Israeli Air Force*. Schatzki had much experience in the management of a complex type of operation like this and he was appointed Chief Engineer of I.A.I.

However, the firm considered itself the nucleus of a true national aircraft industry creating aircraft specifically for the needs of the State of Israel.\* In **1959** the assembly and later the licensed series production was started of the well known French light jet trainer the Fougat Magister (*'Tzukit'*). In **1960** the first airplane of this type was turned over to the Israeli Air force. [<sup>43</sup>] This production provided the experience to turn to the design and manufacture of aircraft of own design. By **1961** the engineering department under Schatzki had completed the design of the B-101C, a small business type airplane that would be able to transport four or five passengers comfortably over long distances and that would give Israel the much needed means of rapid transportation to the Western world. When, because of marketing considerations, this plan was dropped, other projects were started. (see article on next pages.)

In **1962**, close to the age of 65, Erich Schatzki returned to the United States.

---

\* In this respect the company was most successful [partial list of own products by **2015**, source: Wiki]:  
**Civilian:** *Arava*: medium-sized STOL transport aircraft (no longer in production); *Westwind*: business jet (no longer in production); *Astra/Galaxy*: business jets (now produced for Gulfstream Aerospace as the *G100/G200*); *IAI Avocet ProJet*: very light jet (program cancelled). **Military:** *Lavi* - an Israeli fighter jet, abandoned when the United States refused to fund a F-16 competitor. *Kfir* - fighter jet; *Nammer* - fighter jet, updated version of the *Kfir*; *Nesher* - fighter jet, derivative of the French *Mirage 5*; ELTA-ELI-3001 - *AISIS* - Airborne Integrated SIGINT System; CAEW Conformal Airborne Early Warning Aircraft -

# AERONAUTICAL ENGINEERING



**I.A.I.-BUILT POTEZ-FOUGA** twin-jet Magister trainers for the Israeli air force are on flight line for final tests before delivery. Operational numbers of the aircraft, already in their military markings, have been deleted by the Israeli censor. Magister is the first aircraft ever to be produced in Israel and is used by the air force as both a trainer and close-support fighter.

## Israeli Aim Is Self-Contained Air Industry

By Cecil Brownlow

Tel Aviv—Government-owned Israel Aircraft Industries, now cutting its production teeth on the licensed manufacture of the Potez-Fouga Magister twin-jet trainer, is building toward a diversified, self-contained aviation complex with capabilities ranging from airframe design to avionics development, from major overhauls to the fabrication of ground support equipment.

Headquartered in a sprawl of new administrative buildings, hangars and workshops at Tel Aviv's Lod Airport, I. A. I. is aiming at an all-Israel airframe design as a next step in expansion and self-sufficiency and searching for additional overhaul and license contracts in a number of fields as it seeks to build its internal strength and ability for diversification.

"Our main purpose here," one official says, "is to gain a degree of self-sufficiency because we can see where Israel could be cut off from the outside [by her Arab neighbors]."

Another factor is simple necessity. At present, in support of the Israeli air force, El Al Israel Airlines and foreign contractors, France foremost among them, I. A. I. is performing major overhauls on more than 25 different types of airframes—from gliders to Sud Vautour attack bombers—and 30 piston and jet engines—from 90-hp. Continental C90s to 7,720-lb.-thrust Snecma Atar 101E-3s.

Besides having numerous different types of aircraft and engines to contend with, "we are so far away from everyone, we can't send back to the manufacturer everytime we need something, so we have to develop our own capability," says Chief Engineer Erich Schatzki, a U.S. citizen who was a pre-World War 2 test pilot for Deutsche Lufthansa Airlines, an engineer at Germany's Junkers, Fokker and Heinkel and, later, at the U.S.'s Republic Aviation Corp.

I. A. I. had hopes of establishing its own design capability with the development and manufacture of a nine-place twin-jet executive transport, the B-101C, that would have had a U.S. sales price of approximately \$350,000 fully equipped (AW Mar. 6, p. 87; Apr. 10, p. 108).

It recently decided to back away, however, primarily because of the mounting number of similar, competitive designs being introduced in Europe, the United Kingdom and America. Another factor was the lack of expected financial, assembly and distribution aid which I. A. I. had hoped to obtain from an established U. S. firm.

Instead, the Israeli company is planning development of a Gulfstream-size turbojet transport with short takeoff and landing traits in an effort to introduce an aircraft with sufficient market potential and which also can fill a gap in the present development spectrum.

The aircraft has been studied in both

two- and four-engine configurations, but the former apparently is favored, at least for the present. Projected engines reportedly are in the 7,000-lb.-thrust class. Explaining the decision to drop the B-101C after it had progressed beyond the mockup stage, an I. A. I. executive said:

"We looked around, and everybody and his brother had suddenly come up with a small executive jet. So we decided to back off. We've redesigned and refined for better speed, endurance, shorter takeoff and landing rolls. It's a completely new aircraft from the B-101, and it looks good on paper."

No final decision has been reached, however, on proposals that the project be firmly scheduled and plans drafted for phasing into the metal-cutting stage.

I. A. I. "definitely wants to design and build its own aircraft," Schatzki says, "and our present status permits us to build an executive jet. That's why we are primarily interested in this field at the moment."

For the future, Schatzki believes the company will move into the design of utility aircraft and light transports if the market potential seems high enough, and in doing so it undoubtedly will build with an eye on the needs of black Africa, where the Israeli government already is actively establishing firm ties, primarily in the form of technical assistance at present.

The firm also has been considering

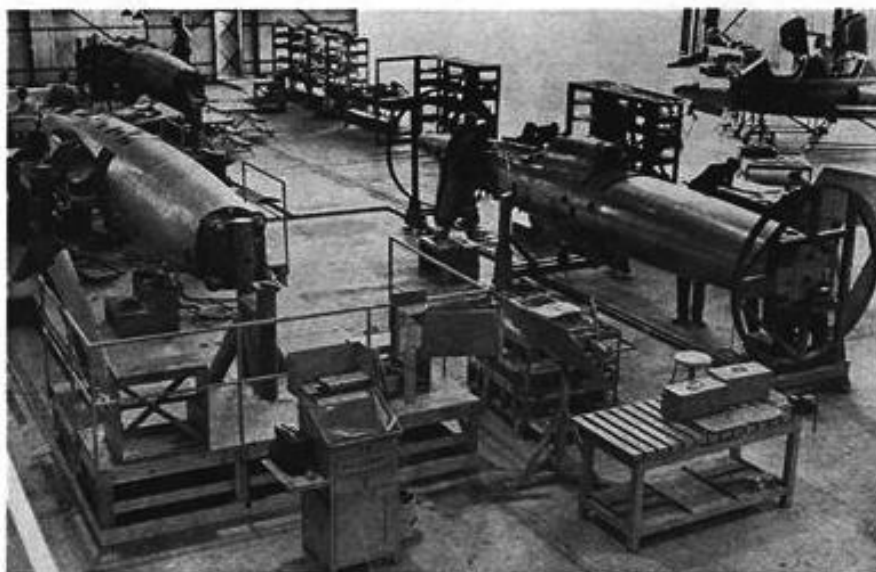

**TECHNICIANS** build up the fuselage sections for three I. A. I. Magister trainers.

the idea" of designing and producing a small helicopter, but there's nothing definite on this," according to Schatzki. "We are primarily interested in [fixed wing] aircraft and airframe systems." Within its workshops, however, I. A. I. is gaining helicopter experience with the overhaul of Sikorsky S-55s and S-58s and the smaller Sud Alouettes for the air force.

It also has modified an Alouette and several small Kolibries for use in agricultural spraying.

#### **Initial Venture**

As in West Germany, the Magister marked Israel's entry into the jet aircraft production field. For Israel, it also was the initial venture into the manufacture of aircraft of any type, and I. A. I., faced with the necessity of taking a major step forward as well as forming a new industry from the talents of engineers, technicians and workmen with origins emanating from around the world, attempted to make the most of it.

"The French might think some of the modifications we are making on the Magister are silly," one engineer here explains, "but we feel we need to do this to build up our own competence. . . . We wanted to use a certain amount of ingenuity to create a background for our capability. . . ."

"We've built our own tooling for instance, which differs from the French tooling, and we think ours is superior in many ways. The French needed a higher rate of production—about 12 a month—and the size and type of tooling reflects this. We never anticipated this rate, so we changed the tooling as we saw fit, simplified and also combined it."

As opposed to the French schedule, present estimated Fouga production

rate here is between two to three aircraft per month.

One of the major changes in tooling was the decision to build the fuselage in a single horizontal jig rather than in the three separate vertical sections which then had to be joined as designed by the French. Over-all savings: four assembly jigs. All I. A. I.-built Magister jigs also have optical tooling, while those of French design are largely manual, according to Engineer Seymour Samach, a native New Yorker.

A number of changes have been made in the airframe as well. Perhaps the most important deviation was the decision to substitute two starter generator units—one for each engine—to replace the single unit used on the French-built aircraft. With the French unit, Samach says, "If you lost one engine, you lost your hydraulic and electrical power. . . . So we now have a separate generator for each engine; we've eliminated the gear box in the middle plus the drive shafts, etc., with a considerable savings in weight."

#### **Starter Generator**

The present starter generator system was designed to I. A. I. specifications by the Breeze Corp., of Union, N. J. The experience, according to Schatzki, is an example of the good cooperation the Israeli company has had with U. S. firms. He says:

"Breeze built the units for us, and we tested them here. . . . To do that over such long distances isn't easy. We tested them on the bench, on the ground and in check flights and sent in a lot of requests for changes. Their cooperation was very good."

From I. A. I.'s side, the design and coordination was monitored by Shalom Ostersetzer, an engineer formerly with Britain's Royal Aircraft Establishment

at Farborough. Ostersetzer is one of Schatzki's two principal assistants. His colleague, Samuel Berke, was with Fokker before coming to Israel.

The first I. A. I. Magister came off the line almost two years ago and was turned over to the air force in July, 1960. It had been assembled here from parts supplied from France. The second aircraft had been prefabricated in France but left largely unfinished. By the fourth aircraft, substantially all the airframe work had been shifted to I. A. I.

The Fouga's Turbomeca Marbore 2 powerplant and a majority of the avionic components are still built and assembled in France, however.

### Plastic Components

On the Israeli-built Magisters, other airframe modifications include use of a number of plastic components, an area in which I. A. I. is considered particularly strong.

These include a plastic ventral fin as a substitute for the metal French unit, a plastic tail cone and an all-plastic canopy and frame combination to replace the original, more costly plexiglass and magnesium frame. All of the Fouga junction boxes also are made here—and of plastic as opposed to sheet metal in the original version.

Aside from airframes, it is in electronics where I. A. I. sees its greatest opportunity for the future, and it is erecting a rambling four-story structure to consolidate its activities and expand into original design work.

The company already has an extensive instrument overhaul shop in conjunction with its aircraft maintenance programs and is building a transistorized radio compass under license. It also plans to build a UHF radio under license and is manufacturing a seven-piece nucleonics measuring device of its own design for export as well as sale within Israel.

In another diversification effort, the company is designing and marketing airport ground support equipment, including cranes, hoisting gear and baggage carts.

### Expanding Overhaul Work

For the present, however, I. A. I.'s strength lies primarily in its expanding overhaul work, but it needs—and is capable of—more prime and subcontract production for its assembly lines. Organized in 1952, with most of its growth coming since 1955, I. A. I.'s employment now stands at approximately 3,000 persons, more than 200 of them graduate engineers, and most of the day-to-day effort for the majority lies in overhaul.

There are four lines in the engine overhaul shop to handle the 30 different types of powerplants that now pass

through I. A. I. Company officials say the multitude of engine types moving over a total of four lines causes no great problems so far as the actual work is concerned, and each line has its specialists who only handle one particular type of powerplant.

### Powerplant Types

Of the 30, seven are turbojet and include the Hispano-Suiza Nene 104B for the Dassault Ouragan fighter-bomber, the Atar for the Vautour, the Hispano-Suiza Verdon for the Mystere 4A, the Rolls-Royce Derwent for the Gloster Meteor and the Turbomeca Marbore 2 for the Magister. The latter powerplant is still being phased into the line.

In addition, I. A. I. also is overhauling the 4,120 eshp. Bristol-Siddeley turboprop engines that power El Al's Bristol Britannia transports and is tooling to do the same for the Rolls-Royce Conway bypass powerplants on the Israeli carrier's Boeing 707-420s. It also hopes to eventually take over the Pratt & Whitney JT3Ds for El Al's Boeing 720B transports.

It is in the supply field, and the logistics flow from stockroom to shop, where I. A. I. experiences its biggest headaches, for both the engines and the airframes.

"For the 25 different types of aircraft we overhaul," Schatzki says, "we have to use 76 different electrical plating methods. . . ."

"In aluminum alloys, as an example, the French, British and American are generally alike, but there are differences, and they can be important. So, we have to get sheet metal from all three countries."

All materials are IBM-controlled, but the flow lines can still prove to be difficult.

### Wide Diversification

In its airframe overhaul section, I. A. I. handles most all of the Israeli air force planes—from Cubs to Mysteres—and aircraft phasing out of the military inventory, here or elsewhere, are often modified for civil use. Stearman PT-17 trainers that have served their day with the air force are being converted to agricultural spray uses, and North American P-51 fighters have been modified in the past to two-seater configurations for executive and sports flying.

Its work also extends beyond the Iron Curtain, with Convair 240s of Poland's Polskie Linie Lotnicze (LOT) airline flying into Tel Aviv for the major engine overhauls.

Yet, I. A. I. is searching for more work in almost all fields. "In general," Schatzki concludes, "I think we are not inclined to say 'No' when something comes up."

# 20. 1962-1969 Erich Schatzki (age 65), retirement in USA

1963 Chief Engineer at Halm Instrument Co. N.Y.

Halm, a small company with big ideas, was founded in 1945 and quickly became the world leader in envelope printing equipment. Today we are still owned and operated by the family of one of the founders. The company focuses on innovation and customer service, a tradition that is responsible for our and your success. This strong focus, coupled with our nearly 100% attention to the envelope printing industry gives us an excellent insight into today's changing print markets. Our employees have a can do attitude, giving Halm the ability to say "Yes We Can" to all of our customers. With offices around the world, a small Company with Global experience!

FRAGMENT of a 1965 patent application (2 of 28 pages):

## United States Patent Office

3,377,772

Patented Apr. 16, 1968

1

3,377,772

### AUTOMATIC WRAPPING MEANS

Floyd A. Lyon, Brookville, Erich Schatzki, New York, Alvin Arnell, Brooklyn, and Clement R. Konazewski, Glen Cove, N.Y., assignors to Halm Instrument Co., Inc., Glen Head, N.Y.

Filed June 14, 1965, Ser. No. 463,662  
9 Claims. (Cl. 53-229)

### ABSTRACT OF THE DISCLOSURE

Means to automatically wrap bundles and articles comprising a bundle receiving platform, means to feed and clamp a web of heat sealable plastic at a first work location, means to clamp said web in a vertical plane, means to push said bundle against said web completely past said vertical plane of said web thereby wrapping said material in a loop around said bundle, means to heat seal the ends of said loop, and means to cut said loop from said web and reseal said web, means to advance said web and clamp it at a point after said seal reuniting said web so that the web is ready for another bundle, means to move said partially heat sealed bundle onto a collapsible table at a second work location, first fixed heat sealing means at said second work location, second motor driven movable side sealing means at said second work location.

This invention relates to automatic wrapping means and more particularly to means for automatically wrapping bundles such as envelopes, papers or other articles.

More specifically the invention provides means for wrapping bundles of envelopes, paper or other articles of variable sizes.

The present invention provides means to wrap bundles and articles comprising a bundle receiving platform and means to feed and clamp a web of heat sealable plastic at a first work location, means to clamp said web in a vertical plane, means to push said bundle against said web completely past said vertical plane of said web thereby wrapping said material in a loop around said bundle, means to heat seal the ends of said loop, and means to cut said loop from said web and reseal said web, means to advance said web and clamp it at a point after said seal reuniting said web so that the web is ready for another bundle, means to move said partially heat sealed

2

Another object of the invention is to provide new and improved heat sealing means.

Another object of the invention is to provide new and improved heat sealing means which are movable to accommodate various sizes of bundles or articles.

Another object of the invention is to provide new and improved bundle wrapping means comprising, means to feed a web of heat sealable wrapping material, a bundle receiving platform, means to feed and clamp said web in a first plane at a first work location, means to push said bundle along an axis perpendicular to said plane against said web and completely past said first plane to form a loop of said wrapping material around said bundle, means to heat seal the ends of said loop, means to cut said loop from said web and reseal said web, means to take up said web in a forward direction and clamp said web after the point where it has been resealed, a table collapsible in a one plane at a second work location, means to move said end sealed bundle along said axis onto said table, first stationary side heat sealing means at said second work location, second side sealing means at said second work location, said second side sealing means being adapted to move perpendicular to said axis to collapse said table to permit snug side sealing of said bundle, and means to eject said bundle from said second work location.

These and other objects of the invention will be apparent from the following specification and drawings of which:

FIGURE 1 is a perspective exploded view of an embodiment of the invention.

FIGURES 1A through 1E are diagrams illustrative of the invention.

FIGURE 2 is a perspective view of the pushing and loading mechanism.

FIGURE 3 is a diagram illustrating the package feeding mechanism.

FIGURE 4 is a perspective view of the control cam mechanism.

FIGURE 5 is a perspective view of the end sealer snubbing roller.

FIGURE 6 is a perspective view of the package film drive.

FIGURES 7 and 7A are diagrams illustrating the operation of the sliding table.

FIGURE 8 is a schematic side view of the end sealer.

April 16, 1968

F. A. LYON ETAL  
AUTOMATIC WRAPPING MEANS

3,377,772

Filed June 14, 1965

21 Sheets-Sheet 1

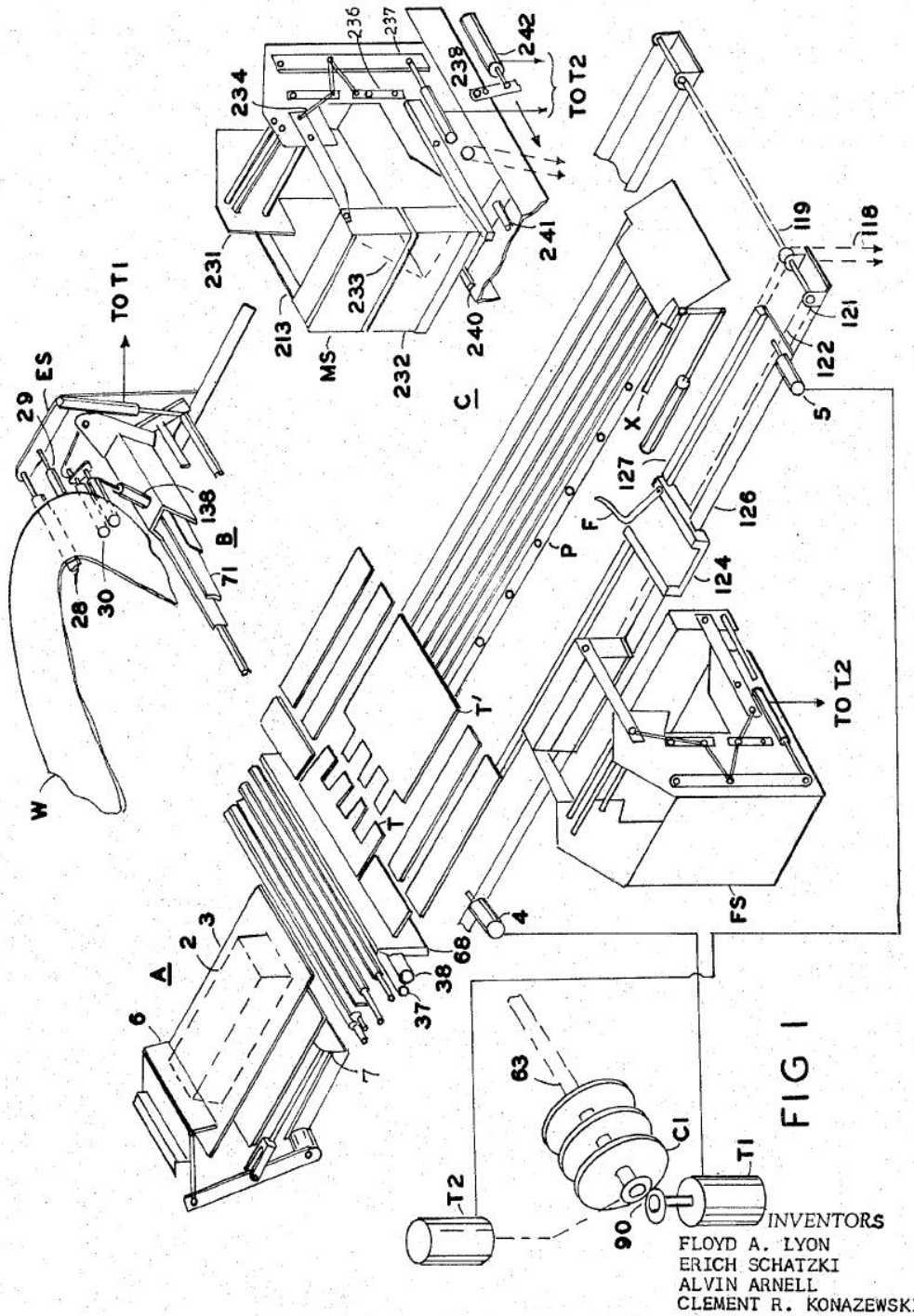

1965 Construction Engineer at Bilnor, builder swimming pools, Long Isl.

April 25, 1967

E. SCHATZKI ETAL  
SWIMMING POOL STRUCTURE

3,315,278

Filed Aug. 18, 1965

5 Sheets-Sheet 5

FIG. 10

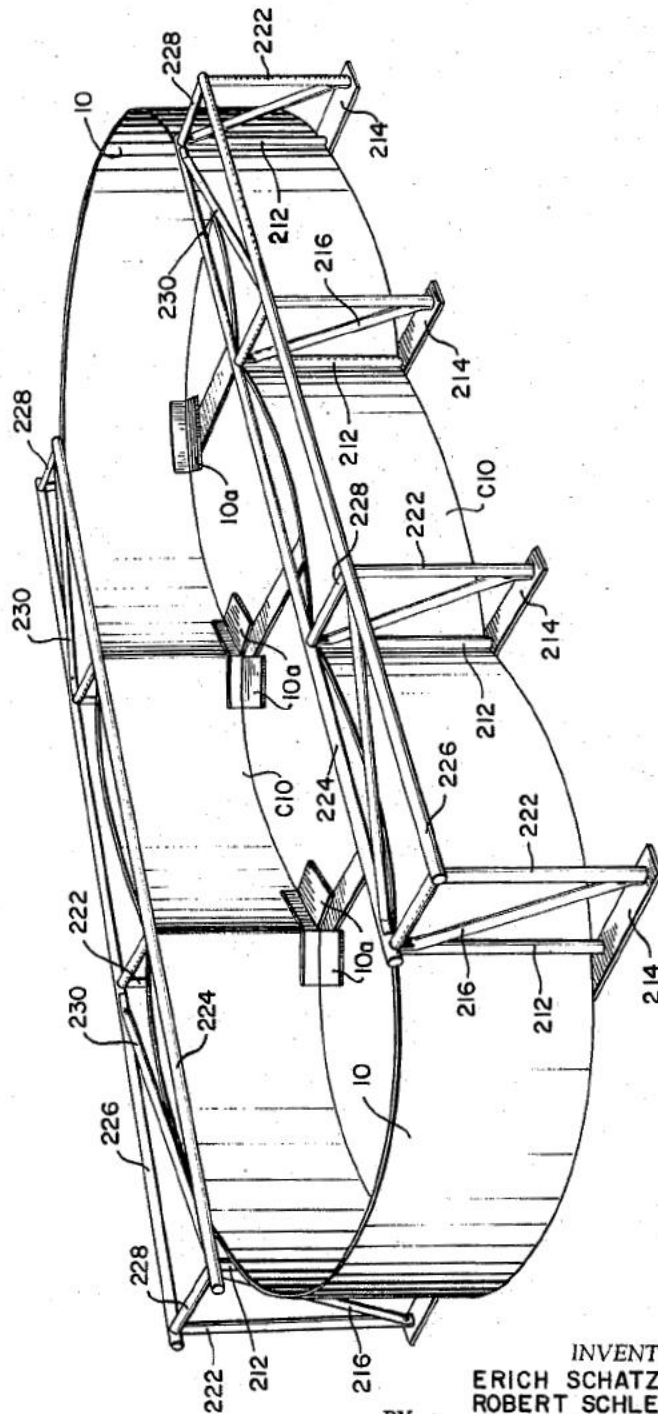

BY

INVENTORS  
ERICH SCHATZKI  
ROBERT SCHLEWEISS  
KENNETH RICHARDSON

*Garry & Garry*  
ATTORNEYS

## 1966: Visit to The Netherlands



In **August 1966** Erich Schatzki was for holidays in Europe and he used the occasion to visit in The Netherlands with Fokker president *ir. H.C.van Meerten* who learned the fine tricks of aircraft design under his guidance in the years 1934-1938. He also met *Henk Barto* again, now Head of the Draughting department that was at this time detailing the design of the Fokker Fellowship jetliner. <sup>[44]</sup> For further memories of Schatzki on his time at Koolhoven, see 13. Erich Schatzki's Flight; Work at N.V. KOOLHOVEN, Rotterdam.

## January 23, 1968

<p>der finnischen Parteipolitik hat er sich zwar lange und kräftig</p>	<p>Kanala hätten sie keine Zugeständnisse machen wollen. Als</p>	<p>Freihandelszone vollzogen. Und trotz seiner Treue zum Finnisch-Sowjetischen Freundschaftspakt, der nur im Kriegsfall in Kraft tritt und zwar nur im Falle eines Krieges in Nordosteuropa, hat er die Gleichgewichtspolitik des Vorgängers Paasikivi dadurch ergänzt, dass er Finnland ausdrücklich wieder als einen neutralen Staat bezeichnet. Wie manche Dichter seines Landes verbindet er nationalromantische Träume mit nüchternem Realismus. <b>I. B.</b></p>	<p><b>Zi</b> D den filie ster Deu eine Yor che New und Hit fer lad Z Tag Pre fra niel Reg ver spr</p>
<h3 style="text-align: center;">Erich Schatzki — 70 Jahre</h3>		<p>hatte so an dem Aufbau der israelischen Luftflotte einen beträchtlichen Anteil. In den Memorien von Heinkel wird Erich Schatzki als einer der fähigsten Flugzeugingenieure charakterisiert, ohne die die Deutsche Lufthansa kaum zu ihrer heutigen Stellung gekommen wäre. In den Vereinigten Staaten ist Schatzki noch heute als Berater für die Entwicklung des Flugzeugwesens und des allgemeinen Maschinenbaus tätig. <b>Kurt R. Grossmann</b></p>	
<p>Erich Schatzki, der am 23. Januar seinen 70. Geburtstag feiert, hat in der Flugzeugindustrie eine hervorragende Rolle gespielt. Die Industrie wurde bereits auf den begabten Mann aufmerksam, als er der akademischen Fliegergruppe in Darmstadt 1920-23 angehörte. Die Junkers-Flugzeugwerke holten sich Schatzki. Später ging er zur Deutschen Lufthansa, wo er zum Chefingenieur aufgestiegen, bis 1933 verblieb. Dann wurde er wegen seiner jüdischen Abstammung entlassen.</p>	<p>Aircraft Corporation und bei der holländischen Koolhoven Aircraft Corporation offene Türen, bis er 1940 von Holland fliehen musste. Der damalige Direktor der Lufthansa von Gabriele half ihm, den Nazihäschern zu entkommen. In den USA schenkte er seine Begabung der Republic Aviation Corporation. Inzwischen war der Staat Israel gegründet worden. Schatzki, seit langem überzeugter Zionist, stellte sich dem jungen Staat zur Verfügung und half beim Aufbau der El Al Israel Air Lines. Ende der fünfziger Jahre ging er erneut für vier Jahre nach Israel als Chefingenieur der dortigen Flugzeugfabrik und</p>	<p>Es folgten die Jahre der Wanderung, aber Schatzki fand bei der Swiss Air, bei der Fokker</p>	
<div style="border: 2px dashed black; padding: 10px; text-align: center;"> <p><b>ISRAFI</b></p> <p><i>Show this movie in your home!</i></p> </div>			

From weekly "Ausbau",\* New York, Volume 34, number 4 <sup>[45]</sup>

\* New York City has since 1934 its weekly for Jewish exiles called "Ausbau". In January 1968 it wrote this note.

## **Erich Schatzki – 70 years (translation)**

*Erich Schatzki*, who celebrated his seventieth birthday on January 23 1968, has played an important role in aviation industry. He already received the attention of that branch of industry when he was a member of the student's flying club in Darmstadt from 1920 to 1923. The Junkers Airplane factory offered Schatzki a position. Later he joined Lufthansa where he remained until 1933 in the position of Head of Engineering. He was fired because he was Jewish.

Years of exile followed, but Schatzki was welcomed by Swissair and then by the Dutch Fokker Aircraft Corporation and at Koolhoven Aircraft, until he had to flee The Netherlands in 1940. Von Gablenz, director of Lufthansa, aided him to escape from the Nazi rulers. In the USA Schatzki put his talents to work for the Republic Aviation Corporation.

Meanwhile the State of Israel had been founded. Schatzki, who was a longstanding Zionist, offered his services to the young state and assisted in the start of El Al Israel Airlines. At the end of the fifties he spent again four years in Israel as Head of Engineering of the national aircraft factory. In this way he played an important role in the growth of Israeli aviation.

Ernst Heinkel characterizes in his memoirs Erich Schatzki as a most capable aeronautical engineer without whom Lufthansa would not have been able to obtain its present position. Still today Erich Schatzki is active in the United States as a consultant in the fields of aviation development and mechanical engineering in general.

**Kurt R. Grossmann**

## **USA: 1969, death of first wife**

In **1969**, when Erich Schatzki is 71 years old, his first wife, *Bertha Schatzki*, died (in NY?)  
They had together one son, Thomas, and one daughter, Karin.

## 21. 1970-1977: Erich Schatzki: Retirement in Israel

---

In **1970** Erich Schatzki leaves anew for Israel, where he settles in Tel Aviv.

He is consultant to *Israel Aviation Industries* and member of the *Israel Council for Civil Aviation*.

He also remains a member of the *Institute of Aeronautical Sciences* in the USA.

May **1975**: Erich Schatzki was present at the *Israel Annual Conference on Aviation and Astronautics* at Tel Aviv to read a paper on aircraft design:[<sup>46</sup>]

A75-37425 # **Intuitive design E Schatzki** Israel Ministry of Transport, Israel Ministry of Defense, and Israel Ministry of Commerce and Industry, **Israel Annual Conference on Aviation and Astronautics**, 17th, Tel Aviv and Haifa, Israel, May 21, 22, 1975,

Paper 12 p. The complex character of design parameters occasionally prevent a mathematical or iterative treatment, especially when the design problem is completely novel. The designer is forced to approach it by a method of 'trial and error', which leads his search in a direction of greatest possibility. This process is partially subconscious and may end in an intuitive design solution. It is shown that intuition is composed of two diametrically opposed but interacting phases, one is creative, the other one analytical. The creative one designs, the analytical one criticizes the created design. Both are essential, they can be taught and learned. The deductions are elucidated by two examples, which form part of the design of an aircraft (Author) [<sup>47, 48</sup>]

In **1977** Erich Schatzki was invited to participate at *Stanford University* in a two year course on Engineering Design. He accepted and decided to stay for his remaining years in California.

## 22. 1977-1991 Erich Schatzki: Indian Summer in Palo Alto, USA

---

In 1977 Erich Schatzki was invited *from Israel* to *Stanford University* to participate in a two-year program on aircraft design. He lived in Palo Alto, married to *Hedda Oppenheim* (b.1909).



**Fille au Chat, Hedda Oppenheim**

*Hedda Oppenheim* came to Palo Alto from Israel in **1977** after she married *Erich Schatzki*, who had been invited to teach at Stanford. The couple decided to stay. Today (this was written in **1997**), Oppenheim lives with her adopted daughter, *Michelle Silver*, her son-in-law, and two of her grand children, Eric, 3, and Julia, eight months.

"I still paint and sketch. I adored my work for the press. I was proud that I could meet so many outstanding personalities. The short contact with them enriched my life, since, by drawing them I could catch some of the brilliance they reflected, and keep a fleeting moment of their lives in the folders of my collection."

Read the very touching personal story of Hedda Oppenheim as recounted by *Rewa Hulden-Hodges* in:

[http://www.paloaltoonline.com/weekly/morgue/news/1997\\_Sep\\_3.ARTIST.html](http://www.paloaltoonline.com/weekly/morgue/news/1997_Sep_3.ARTIST.html)

## 23. 1991: Erich Schatzki dies in California

---

Obituary in NY Times:

# Erich Schatzki, 93, A Designer of Aircraft

Published: September 5, 1991

Dr. Erich Schatzki, an internationally known aeronautical engineer and aircraft designer, **died Aug. 28 1991** at a nursing home in Palo Alto, Calif. A resident of Palo Alto, he was 93 years old.

A native of Germany, he became involved in the early development of the aircraft industry there after World War I, joining Junkers, the aircraft builder, and the budding Lufthansa airline as a test pilot and then commercial pilot.

In the United States, he was engaged in the development of the P-47 Thunderbolt fighter. One of his other contributions in the early stages of jet aviation was a system of jet power "pods" that boosted propeller-driven cargo planes lifting off short runways with heavier loads.

Dr. Schatzki is survived by his wife, Hedda Oppenheim, a son, Thomas, of Berkeley, Calif.; a daughter, Karin Arlin, of Huntington, L.I.; and four grandchildren.

## Epitaph



### Erich Schatzki Road, a Street name against Forgetting...

Between the Jumbo Hall (Building 461) and the WD-workshop (Building 465) runs the architecturally most impressive street on the Lufthansa base in Hamburg. "Erich-Schatzki-Weg" is painted on the street signs which have been installed since September 1996.

Read this informative blog (in German) how it came about: [www.heinzherrmann.com/?thema=41](http://www.heinzherrmann.com/?thema=41) <sup>[49]</sup>

---

# Acknowledgement

---

I wish to thank Mr. Wim Snieder for supplying reference information and pointing the way to the use of the Delpher retrieval system of the Koninklijke Bibliotheek in the Hague, The Netherlands. Mr. Snieder is known for his bibliography of Dutch aviation history: "*In Vogelvlucht*" / *Geannoteerde bibliografie over de Nederlandse luchtvaart, vanaf 1784*. Uitgever; Canaletto/Repro Holland; 486 pages, ISBN 9789064697340

---

## Notes & References

---

<sup>1</sup> <http://www.akaflieg.tu-darmstadt.de/geschichte/showpic.php?>

<sup>2</sup> David Irving: „Die Tragödie der deutsche Luftwaffe“ / Aus den Akten und Erinnerungen von Feldmarschall Erhard Milch

<sup>3</sup> [www.heinzherrmann.com/?thema=41](http://www.heinzherrmann.com/?thema=41)

<sup>4</sup> <https://en.wikipedia.org/wiki/Swissair> and <https://de.wikipedia.org/wiki/Swissair>

<sup>5</sup> [https://en.wikipedia.org/wiki/Virginus\\_E.\\_Clark](https://en.wikipedia.org/wiki/Virginus_E._Clark)

<sup>6</sup> [https://en.wikipedia.org/wiki/Curtiss\\_T-32\\_Condor\\_II](https://en.wikipedia.org/wiki/Curtiss_T-32_Condor_II)

<sup>7</sup> Günther Ott: „Die Boeing 247 und die deutsche Schnellverkehrsflugzeug-Entwicklung“, Luftfahrt international!/82 27

<sup>8</sup> Heinkel, Ernst - Thorwald, Jürgen: "Stürmisches Leben"; 431 p. Wilhelm Heyne Verlag 1977 München

<sup>9</sup> [https://en.wikipedia.org/wiki/Heinkel\\_He\\_70](https://en.wikipedia.org/wiki/Heinkel_He_70)

<sup>10</sup> <https://ritstaalman.files.wordpress.com/2014/05/rohrbach-chronicles-5e-versiona4.pdf>

<sup>11</sup> William L. Shirer: "The Rise and Fall of the Third Reich" / A History of Nazi Germany (Simon and Schuster, New York, 1960)

<sup>12</sup> Hartmut Pophanken; "Gründung und Ausbau der 'Weser'-Flugzeugbau GmbH 1933 bis 1939"; (Verlag H.M. Hauschild GmbH: Bremen; 2000)

<sup>13</sup> Dr. Grulich was one of Luft Hansa's managers.

From Heinz Hermann (see above) I understand that the memoirs from Erich Schatzki can be found in the archives of the present Lufthansa. I have had no opportunity to check this myself.

<sup>14</sup> Line Squalls AUG U ST. 1 9 3 3 Vol. 2 No.3 Published monthly by TRANSCONTINENTAL & WESTERN AIR. Inc.

<sup>15</sup> Peter de Jong: "Fokker D.21 – Fokkers laatste eenmotorige jager" 240p. ISBN: 978-90-8616-099-0 Published 2012: <http://www.lanasta.com/>

---

<sup>16</sup> Heinkel, Ernst - Thorwald, Jürgen: "Stürmisches Leben"; 431 p. Wilhelm Heyne Verlag 1977 München

<sup>17</sup> Günther Ott, see earlier

<sup>18</sup> Apparently the machines were assembled and tested by Fokker crews in Atlantic harbors like Cherbourg (F) and Rotterdam. (see Thijs Postma: "Fokker; Bouwer aan de Wereldluchtvaart"; p.99; publ 1979)

<sup>19</sup> <http://www.curassow.com/2dvrc/sscuracao/fokplesman/timeline.html>

<sup>20</sup> <https://ritstaalman.files.wordpress.com/2015/02/atlairpart32.pdf>

<sup>21</sup> <http://www.noordduynnorseman.com/>

<sup>23</sup> <http://www.dutch-aviation.nl/index5/Civil/index5-2%20F20.html>

<sup>24</sup> Peter de Jong, p.14, see earlier

<sup>25</sup> Via *Delpher*: Twents Dagblad 14-11-1935

The Delpher retrieval system of the Koninklijke Bibliotheek (Royal Library) in the Hague, Netherlands allows specific searches in the archives of the national newspapers. To search for items on Schatzki, use:

<http://www.delpher.nl/nl/kranten/results?query=schatzki&page=1&coll=ddd> (thanks to Wim Snieder)

<sup>26</sup> quote from *Dierikx, Marc*: "Fokker: A Transatlantic Biography", Washington, D.C.: Smithsonian Institution Press, 1997. ISBN 1-56098-735-9; page 184

<sup>27</sup> <https://en.wikipedia.org/wiki/Fokker#History>

<sup>28</sup> the above quotes are from: © Osprey Publishing • [www.ospreypublishing.com](http://www.ospreypublishing.com) SERIES EDITOR: TONY HOLMES: "Fokker D.XXI Aces of World War 2"; by *Kari Stenman and Peter de Jong* and may be accessed through:

<http://www.russiannavy.net/uploads/jim/AS%20112.pdf>

<sup>29</sup> photo source: <http://www.strijdbewijs.nl/top/g-1.htm>

<sup>30</sup> The above description is an excerpt from: [https://en.wikipedia.org/wiki/Fokker\\_G.I](https://en.wikipedia.org/wiki/Fokker_G.I)

<sup>31</sup> quotation from [https://en.wikipedia.org/wiki/Frederick\\_Koolhoven](https://en.wikipedia.org/wiki/Frederick_Koolhoven)

<sup>32</sup> next photograph:

<http://4.bp.blogspot.com/-mwYn2YSyoN4/VTyDfHPCujI/AAAAAAAAAPfE/3siaaaPE8uw/s1600/kh5.jpg>

<sup>33</sup> source: Stan Huygens Journaal, De Telegraaf, 13-08-1966 (via Delpher)

<sup>34</sup> [https://en.wikipedia.org/wiki/Koolhoven\\_F.K.58](https://en.wikipedia.org/wiki/Koolhoven_F.K.58)

<sup>35</sup> [https://en.wikipedia.org/wiki/Messerschmitt\\_Bf\\_109](https://en.wikipedia.org/wiki/Messerschmitt_Bf_109)

<sup>36</sup> [https://de.wikipedia.org/wiki/Koolhoven\\_FK.58](https://de.wikipedia.org/wiki/Koolhoven_FK.58) see this link for a rather negative review of the FK.58.

---

<sup>37</sup> “Airplanes, Women and Song – Memoires of a Fighter Ace, Test Pilot and Adventurer”; SYRACUSE UNIVERSITY PRESS; By Boris Sergievsky, with Alan Forsyth and Adam Hochschild; Russian Contributions to American Aviation, p.128

<sup>38</sup> source: Oral History, CHEMICAL HERITAGE FOUNDATION...

<sup>39</sup> „Politik, Wirtschaft, Öffentliches Leben“, edited by Werner Röder, Herbert A. Strauss  
<https://books.google.com/books?id=Mt6c3oFVBz0C&pg=PA641&dq=Erich+Schatzki&hl=en&sa=X&ved=0ahUKEwigm4jkrsvLAhVO2GMKHYPDDpE4ChDoAQgfMAE#v=onepage&q=Erich%20Schatzki&f=false>

<sup>40</sup> Aviation Week, August 10, 1953 see also FLIGHT 1953 (El Al will equip their C-46's, etc.)

<sup>41</sup> Spokesman-Review - Sep 19, 1956, via Google news

<sup>42</sup> This page is copied from: [https://en.wikipedia.org/wiki/Al\\_Schwimmer](https://en.wikipedia.org/wiki/Al_Schwimmer)

<sup>43</sup> See Algemeen Handelsblad July 6, 1960; via Delpher (see also note <sup>24</sup>)

<sup>44</sup> source: Stan Huygens Journaal, De Telegraaf, 13-08-1966 (via Delpher)

<sup>45</sup> see Wiki : <https://de.wikipedia.org/wiki/Aufbau> on last page link to: <https://archive.org/details/aufbau>  
scroll down to year 1968, Volume 34, nummer4

<sup>46</sup> I would love to have a copy of this lecture but have come not further than this entry in a NASA Bibliography:

<sup>47</sup> source: AERONAUTICAL ENGINEERING - A Special Bibliography with Indexes – Supplement 62 –October 1975  
NASA SP-7037(62) - <http://ntrs.nasa.gov/archive/nasa/casi.ntrs.nasa.gov/19760004905.pdf>

<sup>48</sup> search: Google: Proceedings Israel Annual Conference Aviation and Astronautics, 17th, Tel Aviv and Haifa, Israel, May 21, 22, 1975; Copy of paper at: <http://link.springer.com/search?query=Schatzki>

<sup>49</sup> The hi-tech bicycle is Heinz's.